



BargeSafe™ 3NM

LED Barge Light

Installation & Service Manual

BargeSafe™ 3NM

LED Barge Light

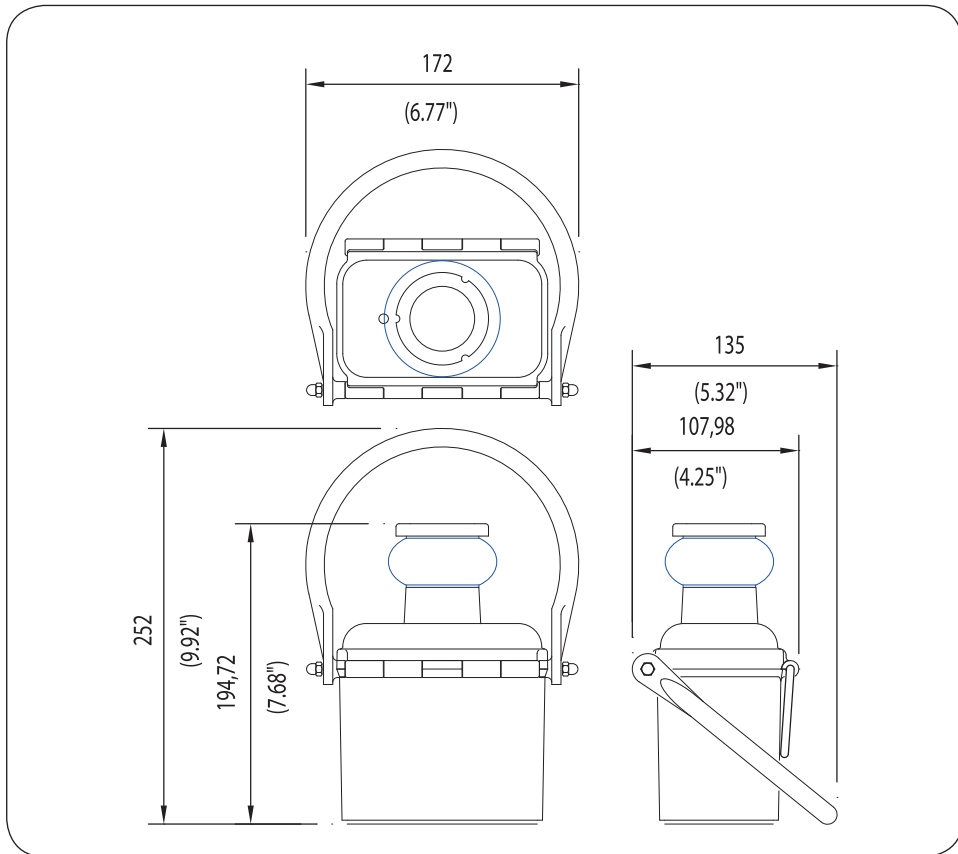

Table of Contents

Introduction	Page 4
Operating Principle	Page 4
Technology	Page 4
BargeSafe™ 3NM Model	Page 5
Application	Page 6
Installation	Page 7
Maintenance & Servicing	Page 8
Trouble Shooting	Page 8
Sealite LED Light Warranty	Page 10

Version No.	Description	Date	Approved
1.0	Manual Launch	May 2009	K. Paton
1.1	Logo and Warranty Update	July 2010	K.Paton
2.0	Update: Spec Table	May 2012	J.Dore
2.1	Remove rechargeable batteries	August 2015	M. Walker
2.2	Update: Contact details	January 2016	J. Dore
2.3	Update: Mounting Spec	April 2018	M.Nicholson

Introduction

Congratulations! By choosing a Sealite BargeSafe™ 3NM you are the owner of one of the most advanced LED marine lights available.

Sealite Pty Ltd has been manufacturing lanterns for over 25 years, and particular care has been taken to ensure your light gives years of service.

The Sealite BL Series comply with requirements for a 3 mile light under international standard UL 1104, Marine Navigation Lights, and has been tested and certified to the relevant sections by Independent Testing Laboratories Inc. Boulder, CO, in 2008.

A Sealite Warranty Registration Card accompanies your lantern and must be returned to validate your warranty.

Operating Principle

The BL Series LED Barge light utilises a small microprocessor to control the required flash rates and monitor the light levels to enable the lantern to turn on automatically at night.

During the day, the BL Series LED Barge light runs a number of self-diagnostic functions.

The power, to a single 1W LED, is provided by a DC/DC convertor, permitting the light to operate on a voltage range of 4V-9V and consistently maintain the required light source intensity.

The BL Series barge lights use the latest advancements in LED (Light Emitting Diode) technology as a light source. As a user, you can expect in excess of 100,000 hours of LED operation, with minimal power consumption.

Technology

Sealite is the world's fastest growing manufacturer of marine aids to navigation. We employ leading mechanical, optical, hardware & software engineers to create innovative products to service the needs of our customers worldwide, and offer the widest range of solar-powered LED lanterns in the marketplace.

Electronics

Sealite employs leading in-house electronic engineers in the design and development of software and related circuitry. All individual electronic components are sourced directly by Sealite procurement staff ensuring that only the highest quality components are used in our products.

LED Technology

All marine lanterns use the latest advancements in LED (Light Emitting Diode) technology as a light source. The major advantage of LED's over traditional light sources is well established in that they typically have an operational life in excess of 100,000 hours, resulting in substantial savings to maintenance and servicing costs.

Precision Construction

Commitment to investing in the design and construction of injection-moulded parts including optic lenses, light bases and a range of other components ensures that all Sealite products are of a consistent & superior quality.

Optical Performance

Sealite manufactures a range of marine LED lenses moulded from multi-cavity dies. Complex shapes such as the SL70, BargeSafe™ and 16-segment multi-focus lenses are a testament to the company's superior in-house lens manufacturing capabilities and outstanding optical performance.

Award-winning, Patented Technology

Several United States and Australian patent registrations are held on Sealite's range of innovative designs, with other regional patents pending in Canada, United Kingdom and Europe.

BargeSafe™ 3NM Model

The Sealite BargeSafe™ 3NM range of LED barge lights are certified to UL 1104 with >3NM visible range.

The LED barge light is one of the most advanced in its class, and incorporates a host of innovative features designed to make the unit extremely user-friendly.

The world-class LED lens is designed by Sealite and achieves precise intensity and sectoring requirements from a single LED light source. This design helps achieve a lower operational current compared with alternate LED barge lights - making the unit ultra efficient and offering a battery run time of up to 75 nights (Air Alkaline Battery).

SPECIFICATIONS*†

BargeSafe™ 3NM

Light Characteristics

Light Source

1 x 1 watt ultra-high intensity LED (sectorised configuration).

Available Colours

Red, Green, White, Yellow as per UL 1104 & COLREG-72

Maximum Available Intensity (cd)*

As per UL 1104 & COLREG-72

Visible Range (NM)

AT @ 0.74: >3NM as per UL 1104 & COLREG-72

AT @ 0.85: >3.5NM as per UL 1104 & COLREG-72

Horizontal Output (degrees)

Red - 112.5° Green - 112.5° White - 135° Yellow - 225° as per UL 1104 & COLREG-72.

Flash Characteristics

As per UL 1104 & COLREG-72 (steady-on & flashing). All round flashing RED

LED Life Expectancy (hours)

>100,000

Electrical Characteristics

Circuit Protection

Integrated

Working Voltage Range (V)

4 - 9

Temperature Range

-40 to 80°C

Power Supply

Battery Type

Air Alkaline (recommended)

Battery Capacity (Ah)

45Ah (Air Alkaline)

Nominal Voltage (V)

6V (Air Alkaline)

Autonomy (days)

>45

Physical Characteristics

Battery Housing

LEXAN® Polycarbonate – UV-stabilised

Lens Material

Acrylic

Lens Mount & Top

Anodised aluminium

Lens Design

Internal single LED cavity with individual sectoring compartments to meet all UL 1104 & COLREG-72 angles for light output. Internal 3 x LED cavities to suit 360° all round light configuration

Mounting

2 x magnets

Height (mm/inches)

195 / 7²/₈

Width (mm/inches)

172 / 6⁷/₈

Depth (mm/inches)

108 / 4¹/₄

Mass (kg/lbs)

1.5 / 3¹/₃

Product Life Expectancy

Up to 12 years

Certifications

Approvals

UL 1104, COLREG-72

IALA

Signal colours compliant to IALA E-200-1

Quality Assurance

ISO9001:2008

Waterproof

IP67

Intellectual Property

Trademarks

SEALITE® is a registered trademark of Sealite Pty Ltd
BargeSafe™ is a trademark of Sealite Pty Ltd



• Specifications subject to change or variation without notice

* Subject to standard terms and conditions

† Intensity setting subject to solar availability

Application

Please check with your local authority before installing the Sealite BargeSafe™ lantern to ensure the position and range is appropriate for your requirements.

- The Stern (White) Barge light provides an angle of 135°.
- The Port (Red) Barge lights provide an angle of 112.5°.
- The Starboard (Green) Barge lights provide an angle of 112.5°.
- The Flashing (Yellow) Barge light provides an angle of 225°.

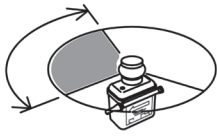

GREEN (112.5°)

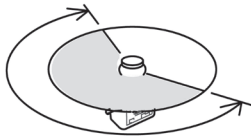

YELLOW (225°)

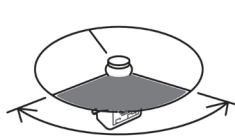

RED (112.5°)

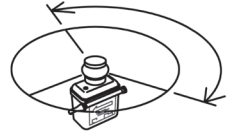

WHITE (135°)

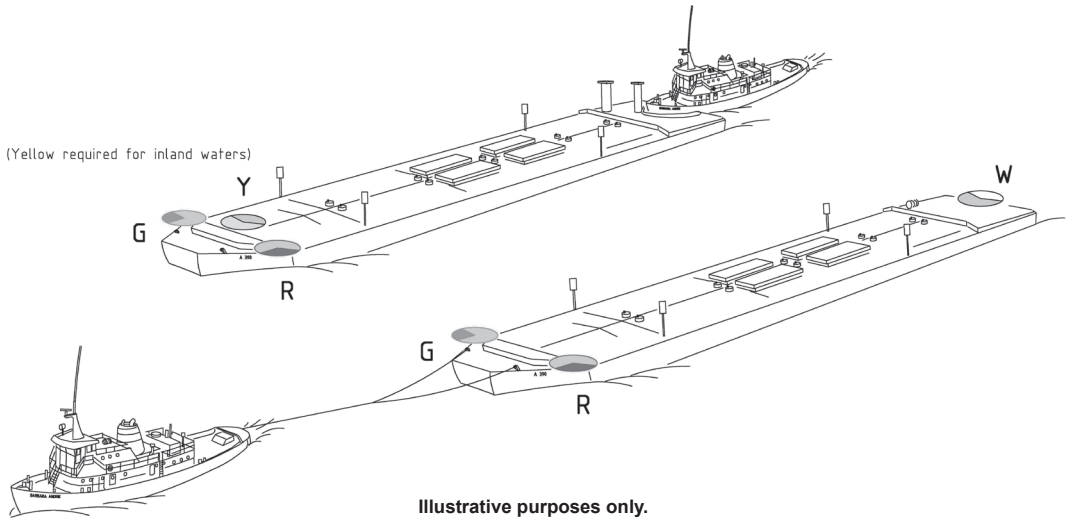

Installation

Installing a 6V Battery

1. Remove any packing material from the light and withdraw the Locking Pin.
2. Open the Lid and insert the battery into the compartment.
3. Ensure the battery is fully inserted in the case. The terminals on the battery must be positioned at the top so they make contact with the contact plate in the lid of the light.
4. Close the lid and insert the Locking Pin.

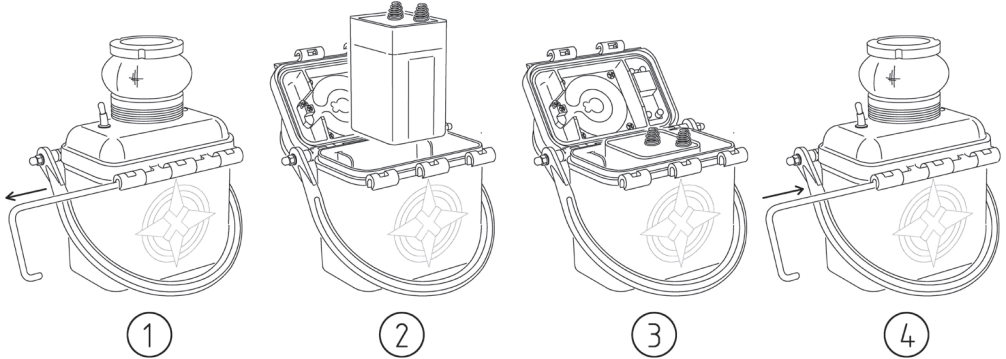

Testing the BargeSafe™ 3NM Light

1. Activate the BargeSafe™ 3NM by turning the toggle switch to the 'ON' position.
2. Place the light in darkness for approximately 1 minute. E.g. a dark room or cover over the light.
3. If the light does not activate within this time, check the following.

- Is the light turned on?
- Is the battery correctly installed?
- Is it dark enough?

Low Battery Status

The BargeSafe™ 3NM will run for many nights on a single 6V Dry Cell Battery. As a number of battery brands may be used in this unit, the number of nights the BargeSafe™ 3NM will operate for will vary.

The BargeSafe™ 3NM will start to flash once every 10 seconds when the battery charge drops below 3.7V.

The BargeSafe™ 3NM will stop operating when the battery drops below 3.5V.

Maintenance and Servicing

Designed to be almost maintenance-free, the BargeSafe™ 3NM light requires minimal attention, though the following maintenance information is provided to help ensure the operation of your product.

1. Cleaning Light Sensor - occasional cleaning of the light sensor panel, located on the lid, may be required. Using a cloth and warm soapy water, wipe off any foreign matter before rinsing the panels with fresh water.
2. Replacing the Battery – the battery used in this lantern will require regular replacement. This will depend on the amount of time the lantern is operating. To replace the battery please follow the steps set out under Installation of the BargeSafe™ 3NM.
3. Removal of Discharged Batteries – please remove any discharged dry cell batteries immediately from the lantern to minimise the chance of corrosion and possible damage to the light.
4. Inspecting the Lid Seal – BargeSafe™ 3NM uses a metric o-ring Ø118 x 3.5mm or imperial o-ring BS247. Check the o-ring periodically for any signs of deterioration. Replace if necessary.

***Always dispose of batteries in a manner that cares for the environment.
Please recycle where possible.***

Low Battery Status

The BargeSafe™ 3NM will run for many nights on a single 6V Dry Cell Battery. As a number of battery brands may be used in this unit, the number of nights the BargeSafe™ 3NM will operate for will vary.

The BargeSafe™ 3NM will start to flash once every 10 seconds when the battery charge drops below 3.7V.

The BargeSafe™ 3NM will stop operating when the battery drops below 3.5V.

Trouble Shooting

Problem	Remedy
Lantern will not activate	<ul style="list-style-type: none"> • Ensure lantern is in darkness. • Wait at least 60 seconds for the program to initialise in darkness. • Ensure battery is properly connected. • Ensure battery has sufficient voltage. • Check the Status LED in the light sensor port. If it is flashing the battery charge is insufficient to power the light.
Lantern will not operate for the entire night	<ul style="list-style-type: none"> • Battery needs either recharging or replacement.
Battery is corroding due to water in the compartment	<ul style="list-style-type: none"> • Check the rubber seal is fitted correctly. Make sure there are no cracks or holes in the seal. Make sure a silicon grease is used on the seal for added sealing. • Check the polycarbonate case for cracks or holes.
Lantern will not turn off	<ul style="list-style-type: none"> • Ensure the light sensor is not covered with debris.
Light is flashing, not steady on	<ul style="list-style-type: none"> • Battery charge is low, (below 3.7V) please change battery to ensure safe operation. When the light senses a low battery it will flash for 0.5 seconds every 10 seconds.





Sealite LED Light Warranty V2.2

Activating the Warranty

Upon purchase, the Sealite Pty Ltd warranty must be activated for recognition of future claims. To do this you need to register on-line. Please complete the Online Registration Form at:

www.sealite.com

Sealite Pty Ltd will repair or replace your LED light in the event of electronic failure for a period of up to three years from the date of purchase, as per the terms & conditions below.

Sealite Pty Ltd will repair or replace any ancillary or accessory products in the event of failure for a period of up to one year from the date of purchase, as per the terms & conditions below.

The unit(s) must be returned to Sealite freight prepaid.

Warranty Terms

1. Sealite Pty Ltd warrants that any Sealite marine products fitted with telemetry equipment including but not limited to AIS, GSM, GPS or RF ("Telemetry Products") will be free from defective materials and workmanship under normal and intended use, subject to the conditions hereinafter set forth, for a period of twelve (12) months from the date of purchase by the original purchaser.
2. Sealite Pty Ltd warrants that any BargeSafe™ Series of LED barge light products ("BargeSafe™ Products") will be free from defective materials and workmanship under normal and intended use, subject to the conditions hereinafter set forth, for a period of twelve (12) months from the date of purchase by the original purchaser.
3. Sealite Pty Ltd warrants that any LED area lighting products ("Area Lighting Products") but not including sign lighting products will be free from defective materials and workmanship under normal and intended use, subject to the conditions hereinafter set forth, for a period of twelve (12) months from the date of purchase by the original purchaser.
4. Sealite Pty Ltd warrants that any ancillary products and accessories, not mentioned in other clauses in this section, will be free from defective materials and workmanship under normal and intended use, subject to the conditions hereinafter set forth, for a period of twelve (12) months from the date of purchase by the original purchaser.
5. Sealite Pty Ltd warrants that any LED sign lighting products ("Sign Lighting Products") will be free from defective materials and workmanship under normal and intended use, subject to the conditions hereinafter set forth, for a period of three (3) years from the date of purchase by the original purchaser.
6. Sealite Pty Ltd warrants that any Sealite marine lighting products other than the Telemetry Products, BargeSafe™ Products, and Area Lighting Products ("Sealite Products") will be free from defective materials and workmanship under normal and intended use, subject to the conditions hereinafter set forth, for a period of three (3) years from the date of purchase by the original purchaser.
7. Sealite Pty Ltd will repair or replace, at Sealite's sole discretion, any Telemetry Products, BargeSafe™ Products, Area Lighting Products or Sealite Products found to be defective in material and workmanship in the relevant warranty period so long as the Warranty Conditions (set out below) are satisfied.
8. If any Telemetry Products, BargeSafe™ Products, Area Lighting Products or Sealite Products are fitted with a rechargeable battery, Sealite Pty Ltd warrants the battery will be free from defect for a period of one (1) year when used within original manufacturer's specifications and instructions.
9. Buoy products are covered by a separate 'Sealite Buoy Warranty'.

Warranty Conditions

This Warranty is subject to the following conditions and limitations;

1. The warranty is applicable to lanterns manufactured from 1/1/2009.
2. The warranty is void and inapplicable if:
 - a. the product has been used or handled other than in accordance with the instructions in the owner's manual and any other information or instructions provided to the customer by Sealite;
 - b. the product has been deliberately abused, or misused, damaged by accident or neglect or in being transported; or
 - c. the defect is due to the product being repaired or tampered with by anyone other than Sealite or

authorised Sealite repair personnel.

3. The customer must give Sealite Pty Ltd notice of any defect with the product within 30 days of the customer becoming aware of the defect.
4. Rechargeable batteries have a limited number of charge cycles and may eventually need to be replaced. Typical battery replacement period is 3-4 years. Long term exposure to high temperatures will shorten the battery life. Batteries used or stored in a manner inconsistent with the manufacturer's specifications and instructions shall not be covered by this warranty.
5. No modifications to the original specifications determined by Sealite shall be made without written approval of Sealite Pty Ltd.
6. Sealite lights can be fitted with 3rd party power supplies and accessories but are covered by the 3rd party warranty terms and conditions.
7. The product must be packed and returned to Sealite Pty Ltd by the customer at his or her sole expense. Sealite Pty Ltd will pay return freight of its choice. A returned product must be accompanied by a written description of the defect and a photocopy of the original purchase receipt. This receipt must clearly list model and serial number, the date of purchase, the name and address of the purchaser and authorised dealer and the price paid by the purchaser. On receipt of the product, Sealite Pty Ltd will assess the product and advise the customer as to whether the claimed defect is covered by this warranty.
8. Sealite Pty Ltd reserves the right to modify the design of any product without obligation to purchasers of previously manufactured products and to change the prices or specifications of any product without notice or obligation to any person.
9. Input voltage shall not exceed those recommended for the product.
10. Warranty does not cover damage caused by the incorrect replacement of battery in solar lantern models.
11. This warranty does not cover any damage or defect caused to any product as a result of water flooding or any other acts of nature.
12. There are no representations or warranties of any kind by Sealite or any other person who is an agent, employee, or other representative or affiliate of Sealite, express or implied, with respect to condition of performance of any product, their merchantability, or fitness for a particular purpose, or with respect to any other matter relating to any products.

Limitation of Liability

To the extent permitted by acts and regulations applicable in the country of manufacture, the liability of Sealite Pty Ltd under this Warranty will be, at the option of Sealite Pty Ltd, limited to either the replacement or repair of any defective product covered by this Warranty. Sealite will not be liable to Buyer for consequential damages resulting from any defect or deficiencies.

Limited to Original Purchaser

This Warranty is for the sole benefit of the original purchaser of the covered product and shall not extend to any subsequent purchaser of the product.

Miscellaneous

Apart from the specific warranties provided under this warranty, all other express or implied warranties relating to the above product is hereby excluded to the fullest extent allowable under law. The warranty does not extend to any lost profits, loss of good will or any indirect, incidental or consequential costs or damages or losses incurred by the purchaser as a result of any defect with the covered product.

Warrantor

Sealite Pty Ltd has authorised distribution in many countries of the world. In each country, the authorised importing distributor has accepted the responsibility for warranty of products sold by distributor. Warranty service should normally be obtained from the importing distributor from whom you purchased your product. In the event of service required beyond the capability of the importer, Sealite Pty Ltd will fulfil the conditions of the warranty. Such product must be returned at the owner's expense to the Sealite Pty Ltd factory, together with a photocopy of the bill of sale for that product, a detailed description of the problem, and any information necessary for return shipment.



We believe technology improves navigation™

sealite.com | info@sealite.com

Sealite Pty Ltd
Australia
+61 (0)3 5977 6128

Sealite Asia Pte Ltd
Singapore
+65 6908 2917

Sealite United Kingdom Ltd
UK
+44 (0) 1502 588026

Sealite USA LLC
USA
+1 (603) 737 1311