

Copyright. All information furnished within this document, electronic file or design correspondence is the property of Den Hartog industries, Inc. and shall not be used, disclosed to others or copied without the expressed written consent of Den Hartog Industries, Inc.

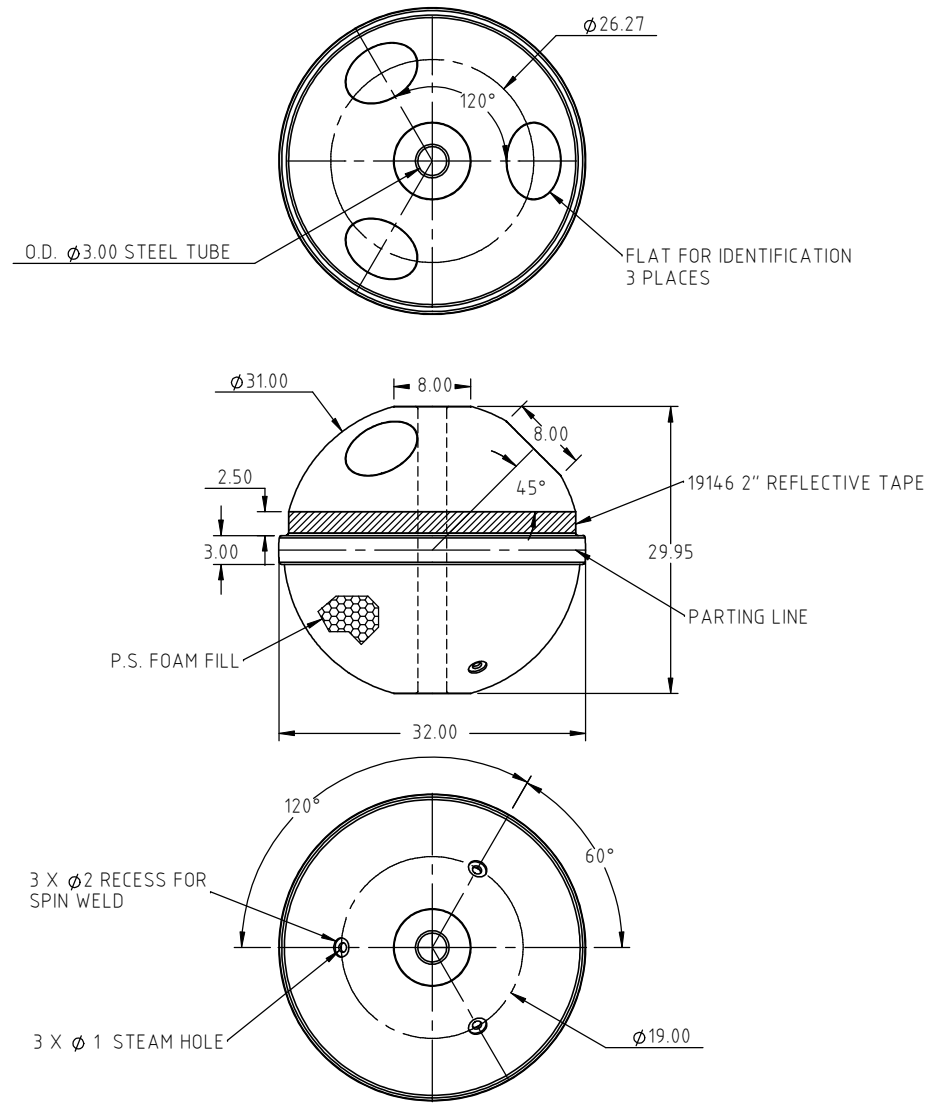

PACKAGE IN 19147 CARTON

				DRAWN / DATE ADH 7/20/10	MATERIAL 10948
				APPRD. / DATE REH 10/26/10	
REV	DESCRIPTION	BY / DATE	CCN		
ALL DIMENSIONS ARE IN DECIMAL INCHES TOLERANCES UNLESS OTHERWISE SPECIFIED		THIRD ANGLE PROJECTION ANSI 14.5M		SHOT WEIGHT: 26.0 LBS	NOTES: 1.) .200 WALL 2.) 9.4 LBS FOAM
POLYETHYLENE ±1% @ 68°F		METAL DECIMAL ± .125" FRACTION ± 1/4" ANGLE ± 1°		SHIPPING WEIGHT: 49.0 LBS	
		FINISH:			



Den Hartog
INDUSTRIES, INC.

Acce Roto-Mold Injection Molding Blow Molding Blowjey

4010 HOSPERS DRIVE S. BOX 425, HOSPERS, IOWA 51238-0425

DESCRIPTION 32 INCH FOAM FILLED MORING BUOY	
SCALE N.S.	PART NO. FFMB-3232