



SL-07, SL-C310 & SL-C410
Marine Lanterns
Installation & Service Manual



Version No.	Description	Date	Approved
1.0	Manual Launch: SL-C410 added & IR Control	March 2012	C. Procter
1.1	Addition of Configuration Settings Information	April 2012	S. Turner
1.2	Configuration Settings update	April 2012	C. Procter
1.3	Addition of LUX Table	April 2012	J. Dore
1.4	Update to Max Intensities & Addition of Automatic Intensity Reduction	June 2012	C. Procter
2.0	GPS as standard	Nov 2012	C. Procter
3.0	Lantern Operation Update, Specs & GSM (SL-C410) IR Controller functions	January 2014	P. Rainey/ Y. Chambers/ S. Turner

Table of Contents

Introduction	Page 4
Operating Principle	Page 4
Technology	Page 4
SL-07 Model	Page 5
Installation of SL-07 Model	Page 6
SL-C310 & SL-C410 Models	Page 7
Installation of SL-C310 & SL-C410 Models	Page 10
Selecting an Intensity/Power Setting	Page 11
Selecting a Flash Code	Page 12
Flash Codes	Page 13
GPS Synchronisation	Page 18
Lantern Status	Page 19
Optional IR Remote Control	Page 21
Sealite IR Controller / Universal Remote Compatibility	Page 21
IR Controller Functions	Page 22
Test Mode / Configure.....	Page 22
Normal Operation.....	Page 22
Read	Page 22
Flash Code.....	Page 23
Flash Code Numbers	Page 23
Intensity.....	Page 23
Battery Status	Page 23
Lux	Page 24
Error / Acknowledge Indication	Page 25
Configuration Settings.....	Page 25
Hibernation Mode (Advanced Users).....	Page 26
Storage Mode (Advanced Users).....	Page 28
Optional GSM Monitoring & Control System	Page 29
Maintenance & Servicing	Page 29
SL-07 Model.....	Page 29
SL-C310 & SL-C410 Models.....	Page 30
Replacing the Battery (SL-C310 & SL-C410 Models).....	Page 30
Long Term Battery Storage (SL-C310 & SL-C410 Models)	Page 30
Solar Panel Replacement (SL-C310 & SL-C410 Models).....	Page 31
How to Change the Regulator (SL-C310 & SL-C410 Models).....	Page 32
Trouble Shooting	Page 33
SL-07 Model.....	Page 33
SL-C310 & SL-C410 Models.....	Page 33
Sealite LED Light Warranty	Page 34



Introduction

Congratulations! By choosing to purchase a Sealite lantern you have become the owner of one of the most advanced LED marine lanterns in the world.

Sealite Pty Ltd has been manufacturing lanterns for over 25 years, and particular care has been taken to ensure your lantern gives years of service.

As a commitment to producing the highest quality products for our customers, Sealite has been independently certified as complying with the requirements of ISO9001:2008 quality management system.

Sealite lanterns comply with requirements of the US Coast Guard in 33 CFR part 66 for Private Aids To Navigation.

By taking a few moments to browse through this booklet, you will become familiar with the versatility of your lantern, and be able to maximise its operating function.

Please remember to complete the Sealite warranty registration card accompanying your lantern.

Operating Principle

The solar module of the lantern converts sunlight to an electrical current that is used to charge the battery. The battery provides power to operate the lantern at night.

The flasher unit has very low current requirements. A microprocessor drives an ultra bright LED through a DC/DC converter, which enables the LED to operate within the manufacturer's specifications. The battery is protected from over-charging within the circuit to ensure maximum battery life.

On darkness, the microprocessor will initiate a program check and after approximately 1 minute begin flashing to the set code

Technology

Sealite is the world's fastest growing manufacturer of marine aids to navigation. We employ leading mechanical, optical, hardware & software engineers to create innovative products to service the needs of our customers worldwide, and offer the widest range of solar-powered LED lanterns in the marketplace.

Electronics

Sealite employs leading in-house electronic engineers in the design and development of software and related circuitry. All individual electronic components are sourced directly by Sealite procurement staff ensuring that only the highest quality components are used in our products.

LED Technology

All marine lanterns use the latest advancements in LED (Light Emitting Diode) technology as a light source. The major advantage of LED's over traditional light sources is well established in that they typically have an operational life in excess of 100,000 hours, resulting in substantial savings to maintenance and servicing costs.

Precision Construction

Commitment to investing in the design and construction of injection-moulded parts including optic lenses, light bases and a range of other components ensures that all Sealite products are of a consistent & superior quality.

Optical Performance

Sealite manufactures a range of marine LED lenses moulded from multi-cavity dies. The company has superior in-house lens manufacturing capabilities to support outstanding optical performance.

Award-winning, Patented Technology

Several United States and Australian patent registrations are held on Sealite's range of innovative designs, with other regional patents pending in Canada, United Kingdom and Europe.

SL-07 Model

1-5nm+ Stand Alone Marine Lantern

The SL-07 is an LED Light Fixture designed to offer superior visibility and operate in conjunction with existing or purpose-built power supplies.

With a variable range of 1 to 5nm+, a maintenance-free light source and 256 user adjustable flash codes, the SL-07 series of LED lights is the preferred choice for buoy manufacturers seeking to fit a marine lantern to existing or independently designed power sources.

The SL-07 model is fitted with a GPS unit to synchronise flashing lights over any distance. This model has an IR sensor which allows it to be operated via Sealite's IR remote control.

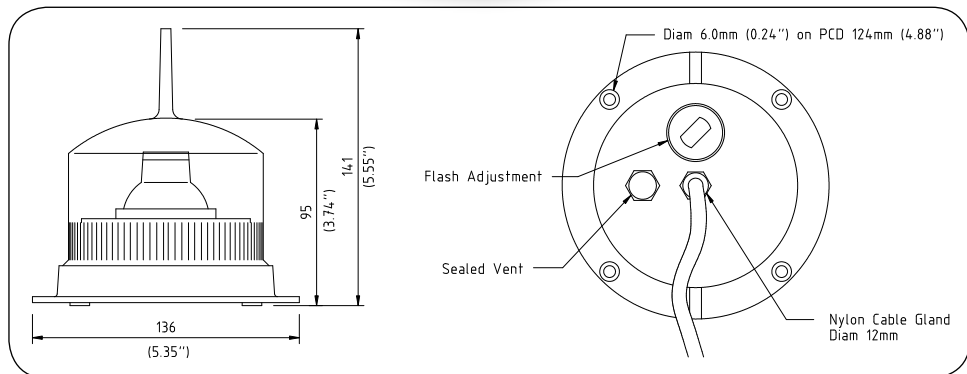
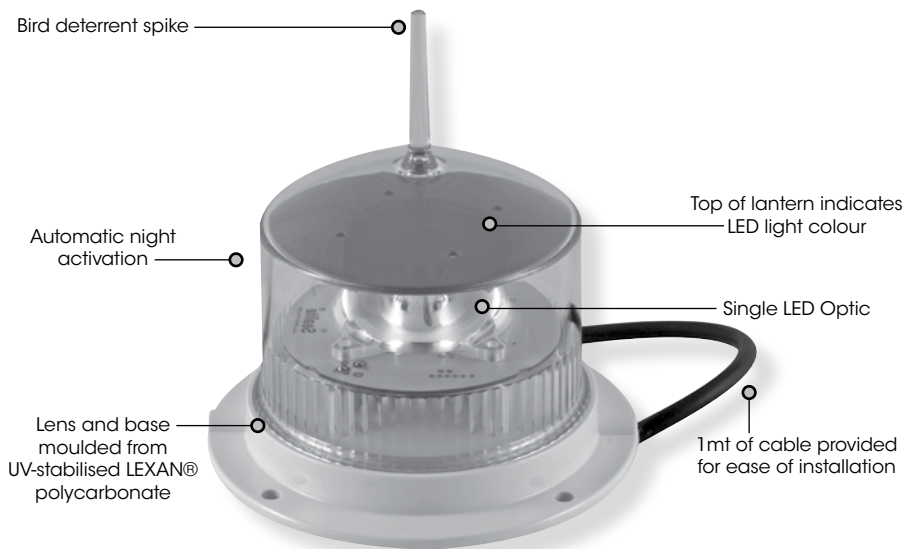

SPECIFICATIONS * * **SL-07**

Light Characteristics

Light Source	1 LED
Available Colours	Red, Green, White, Yellow, Blue
Typical Maximum Flashing Intensity (cd)†	Red - 121 Green - 88 White - 156 Yellow - 95
Visible Range (nm)	1-5+
Horizontal Output (degrees)	360
Vertical Divergence (degrees)	7
Available Flash Characteristics	Up to 256 IALA recommended (user adjustable)
Intensity Adjustments	Adjustable in 25% increments
LED Life Expectancy (hours)	>100,000

Electrical Characteristics

Current Draw (mA)	120
Circuit Protection	Integrated
Nominal Voltage (V)	12
Temperature Range	-40 to 80°C

Physical Characteristics

Body Material	LEXAN® Polycarbonate - UV-stabilised
Lens Material	LEXAN® Polycarbonate - UV-stabilised
Lens Diameter (mm/inches)	98 / 3 7/8
Lens Design	Single LED Optic
Mounting	4 x 6mm mounting holes
Height (mm/inches)	141 / 5 1/2
Width (mm/inches)	136 / 5 3/8
Mass (kg/lbs)	0.4 / 7/8
Product Life Expectancy	Up to 12 years

Certifications

CE	EN61000-6-3:1997, EN61000-6-1:1997
Quality Assurance	ISO9001:2008
Waterproof	IP68

Intellectual Property

Trademarks	SEALITE® is a registered trademark of Sealite Pty Ltd
Warranty *	3 years

Options Available

- 50mm pole mount adapter plate
- Additional cable
- Light sensor disabled
- IR Controller

• Specifications subject to change or variation without notice
* Subject to standard terms and conditions
† Intensity setting subject to solar availability



Installation of SL-07 Model

Lantern is activated by the connection of positive and negative wires to battery or mains system. Flash setting needs to be set prior to activation.

1. Remove the marked flash adjustment bung from the base of the lantern and set rotary switches to the required flash code (see 'Selecting a Flash Code' section of this manual).
2. Replace flash adjustment bung.
3. A sealed vent on the base allows air transfer without moisture intake, and should not be disturbed.
4. Battery Connection: Connect "Battery Negative (-)" wire to negative terminal of battery, and "Battery Positive (+)" wire to positive terminal of battery.
Mains Connection: Connect negative and then positive wires to 12volt power supply (ONLY).
5. To test place dark cover (towel or jacket) on top of light to activate sensor, light will come on within one minute.
6. Ensure that the unit is bolted to an even, flat surface.

Care must be taken to observe the polarity of each wire before they are connected.

SL-C310 & SL-C410 Models

Compact 3-5nm+ Solar Marine Lanterns

The robust design of this self-contained light ensures up to 12 years of reliable service with minimal ongoing maintenance. Specifically designed to survive the harshest environment the SL-C310 and SL-C410 feature seven stage powder coated aluminium Top, Base and Internal Aluminium Chassis. The corners are made from UV stabilised rubber.

All components are user-replaceable in the unlikely event of damage.

The high impact resistant polycarbonate lens ensures even light visibility.

The SL-C310 model has four 3 watt (12watt total) premium-grade solar modules integrated into the solar chassis, and mounted to collect sunlight at all angles. The SL-C410 model has a larger power supply consisting of four 5watt panels (20 watt total) for use in lower sunlight areas or where more demanding duty cycles are required.

The three and four hole bolt pattern will fit directly onto any 200mm OD mount.

The lanterns can be fitted with an optional external ON/OFF switch; this means the light can be turned on once mounted in position, with the flick of a switch. It can also be fitted with an optional external charging port for charging the battery while it is stored for extended periods.

The SL-C310 and SL-C410 models are fitted with a GPS unit to synchronise flashing lights over any distance.

These models have an IR sensor which allows it to be operated via Sealite's IR remote control.

All this is backed by Sealite's industry leading 3-year warranty.



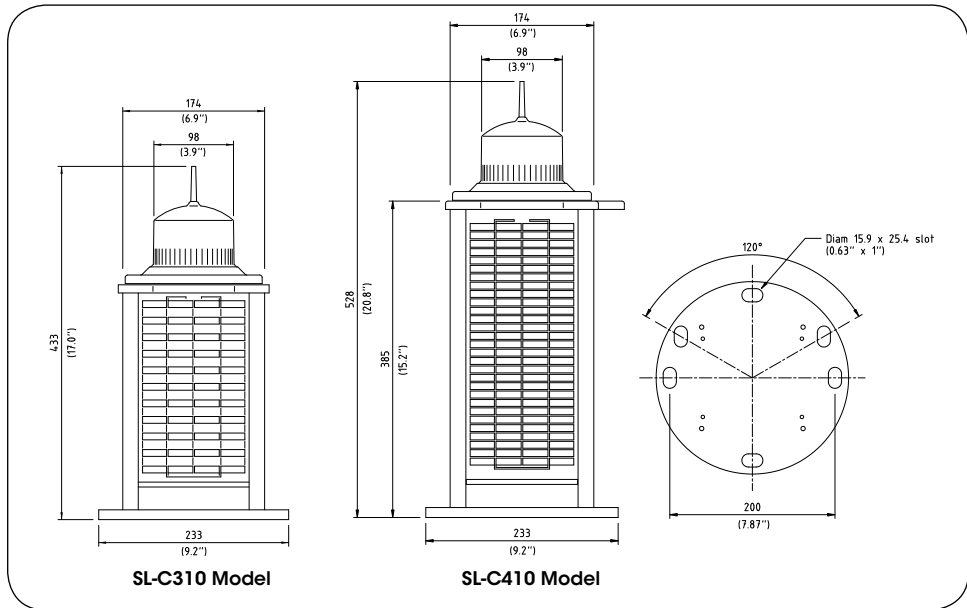
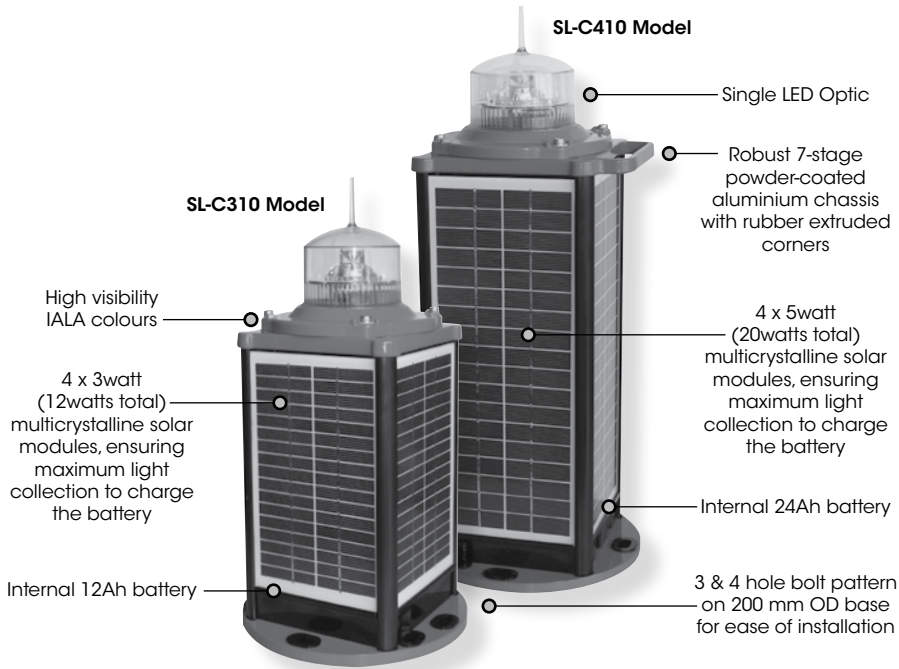

Light Characteristics

Light Source
Available Colours
Typical Maximum Flashing Intensity (cd)†
Visible Range (nm)
Horizontal Output (degrees)
Vertical Divergence (degrees)
Available Flash Characteristics

1 LED
Red, Green, White, Yellow, Blue
Red - 121 Green - 88 White - 156
Yellow - 95
3-5+
360
>7
Up to 256 IALA recommended (user adjustable)
Adjustable in 25% increments
>100,000

1 LED
Red, Green, White, Yellow, Blue
Red - 121 Green - 88 White - 156
Yellow - 95
3-5+
360
>7
Up to 256 IALA recommended (user adjustable)
Adjustable in 25% increments
>100,000

Intensity Adjustments
LED Life Expectancy (hours)

Electrical Characteristics

Current Draw at advertised intensity (mA)
Night Off Current (Eclipse) (mA)
Day Off Current (mA)
Circuit Protection
Nominal Voltage (V)
Autonomy (nights)

120
2.5
0.6
Integrated
12
>60 (14 hour darkness, 12.5% duty cycle)
-40 to 80°C

120
2.5
0.6
Integrated
12
>110 (14 hour darkness, 12.5% duty cycle)
-40 to 80°C

Temperature Range

Solar Characteristics

Solar Module Type
Output (watts)
Charging Regulation

Multicrystalline
12 (4 x 3watt)
Microprocessor controlled

Multicrystalline
20 (4 x 5watt)
Microprocessor controlled

Power Supply

Battery Type
Battery Capacity (Ah)
Nominal Voltage (V)
Battery Service Life

SLA (Sealed Lead Acid)
12
12
Average 5 years

SLA (Sealed Lead Acid)
24
12
Average 5 years

Physical Characteristics

Body Material

7-stage powder-coated aluminium chassis with UV-stabilised rubber corners & gaskets

7-stage powder-coated aluminium chassis with UV-stabilised rubber corners & gaskets

LEXPAN® Polycarbonate - UV-stabilised

98 / 37/8

LEXPAN® Polycarbonate - UV-stabilised

Single LED Optic

98 / 37/8

Mounting

3 & 4 hole 200mm bolt pattern

Single LED Optic

Height (mm/inches)

433 / 17

528 / 20³/₄

Width (mm/inches)

233 / 9¹/₅

233 / 9¹/₅

Mass (kg/lbs)

9.4 / 20³/₄

13.9 / 30¹/₂

Product Life Expectancy

Up to 12 years

Up to 12 years

Certifications

CE
Quality Assurance
Waterproof

EN61000-6-3:1997. EN61000-6-1:1997
ISO9001:2008
IP68

EN61000-6-3:1997. EN61000-6-1:1997
ISO9001:2008
IP68

Intellectual Property

Trademarks

SEALITE® is a registered trademark of Sealite Pty Ltd
3 years

SEALITE® is a registered trademark of Sealite Pty Ltd
3 years

Warranty ***Options Available**

- 50mm pole mount adapter plate
- IR Controller
- External ON/OFF Switch
- External Battery Charging Port
- GPS Synchronisation: enable/disable
- 5° Lens

- 50mm pole mount adapter plate
- IR Controller
- GSM Monitoring & Control System*
- External ON/OFF Switch
- External Battery Charging Port
- GPS Synchronisation: enable/disable
- 5° Lens
- Higher current setting available for high sunlight regions



• Specifications subject to change or variation without notice

* Subject to standard terms and conditions

† Intensity setting subject to solar availability

Installation of SL-C310 & SL-C410 Models

Charging the Battery

New lanterns should be left in the sun for 1-2 days to ensure battery is charged before placing in service. Please note, lantern will re-charge even when toggle switch is turned to 'OFF' position.

Preferred Installation Location

For best lantern performance, ensure solar modules are not covered and are in clear view of the sky with no shadows.

Lantern Operation

Lantern is activated by connecting the battery terminals. Flash setting needs to be set prior to activation.

1. Remove the four socket-head screws on the top lens assembly and open.
2. Remove the bung in the base of the light head.
3. Adjust the Intensity setting using the DIP switches (detailed below)
4. Adjust the rotary switches (A and B) to desired flash setting (see 'Selecting a Flash Code' section of this manual).
5. Replace the bung in the base of the light head.
6. Connect the 4-pin connector together to power up the unit.
7. The unit is now ready for normal operation, once placed in darkness.
8. Close the light head, and replace 4 socket head screws. Sealite recommend that the Light Head be tightened onto the Solar Chassis Base using a general purpose "Grip Tool", similar in shape to a Screwdriver, however with the appropriate Hex Key Head fitted. The torque setting applied to each of the 4 Hex Bolts, be applied sufficient enough, to ensure that the Light Head base is secured firmly, but not over tightened with excessive force. Sealite will not Warrant any product which has been excessively over tightened.
9. To test place dark cover (towel or jacket) on top of light to activate sensor, light will come on within one minute.
10. Ensure that the unit is bolted to an even, flat surface.

Item	Description	Quantity
1	SL-C310 / SL-C410 Base	1
2	SL-C310 / SL-C410 Lens Assembly	1
3	Battery 12v 12Ah	1
4	Battery Clamp	1
5	Washer M4	2
6	M4 Cap Screw	2
7	O-Ring, ID 145 x 4.0	1
8	Socket Head Screw M6 x 20	4
9	Mounting Insert	6

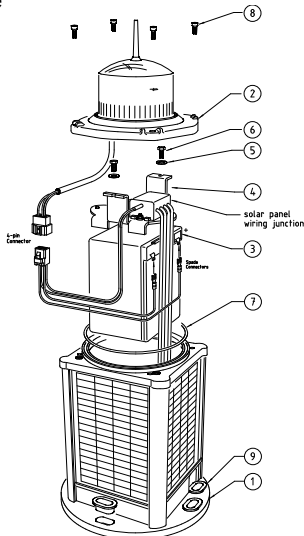

**Fig 2. SL-C310 / SL-C410
Solar Marine Lantern components**

Selecting an Intensity/Power Setting

SL-07, SL-C310 & SL-C410 Models

Intensity/power settings on Sealite lanterns operate via DIP switches, located near the rotary switches on the flasher unit. The intensity/power settings may be used to reduce the power consumption and intensity of the lantern. Setting the lantern to 25% intensity will reduce the power consumption to 25% of the normal 100% setting and the range by 25%. This setting may be used to adjust the current draw of the light to local sunlight conditions.

The following diagrams indicate intensity/power settings:-

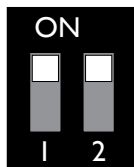

100%

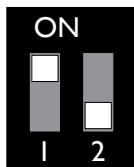

75%

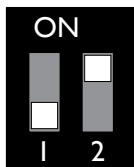

50%

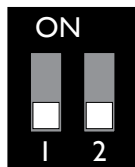

25%

Intensity Setting	Power	White cd	Green cd	Red cd	Yellow cd
100%	120mA	176	88	121	95
75%	94mA	132	66	90	71
50%	64mA	88	44	60	48
25%	35mA	44	22	30	24

Model	Total power used per night (mAh)	Solar Panel Charge (mA)	Number of full sunlight hours required to break even (the amount of time it will take for the solar to replace what the light took out overnight)
SL-07	Not Applicable		
SL-C310	/	277	=
SL-C410	/	435	=

If the number of Full Sunlight hours is less than 2.5-3.0 hours, please consider reducing the intensity (Power) or reducing the Duty Cycle.

Automatic Intensity Reduction for Fixed-On Character

- When the flash code is configured to 00 or 'Steady On', the maximum intensity is set to 50%. If a higher intensity is previously set when the lamp is on, the intensity will automatically fall to the 50% setting when flash code 00 is configured.
- The intensity settings available for lamps with a flash code set to 00 are 25% and 50%. The lamp will flash an error condition if an intensity setting greater than 50% is selected with the IR Remote Control.
- If the flash code is changed from 00 to another value, the maximum allowable intensity reverts back to 100%.

Selecting a Flash Code - Rotary Switches A & B SL-07, SL-C310 & SL-C410 Models

All lanterns have 2 rotary switches marked A and B on the flasher unit. Turning the small arrows to the appropriate number or letter will set the code. The unit may take up to one minute to activate a new flash code. A comprehensive list of available flash codes is listed on in the 'Flash Codes' section of this manual.

Example:

SWITCH		FLASH CODE	ON	OFF
A	B			
A	0	FL 3 S	0.3	2.7

Note – if setting the lantern to a demanding duty-cycle such as steady-on, the power setting must be reduced to ensure reliable operation

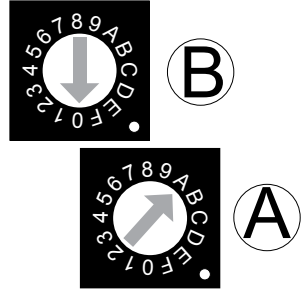

Flash Codes

The Sealite SL-07, SL-C310 & SL-C410 may be set to any of 256 IALA recommended flash settings which are user-adjustable onsite without the need for external devices.

SEALITE® code reference is listed by number of flashes

**For the latest version of this document visit www.sealite.com
or email info@sealite.com**

Symbols

FL	Flash followed by number Eg. FL 1 S, one flash every second
F	Fixed
Q	Quick flash
VQ	Very quick flash
OC	Occulting; greater period on than off
ISO	Isophase; equal period on and off
LFL	Long flash long
MO	Morse code () contains letter

For example, VQ (6) + LFL 10 S means 6 very quick flashes followed by a long flash, during a 10-second interval.

The amount of power your lantern draws through the night depends on the duty cycle, i.e. the amount of time on as a proportion to the timing cycle. For example, 0.5 seconds on and 4.5 seconds off equals a 10% duty cycle.

It is best to operate at the lowest duty cycle appropriate to the actual needs of the application.

Recommended Rhythm for Flashing Light - IALA Regions A and B

MARK DESCRIPTION	RHYTHM
Port Hand & Starboard Marks:	Any, other than Composite Group Flashing (2+1)
Preferred Channel Starboard:	Composite Group Flashing (2+1)
Preferred Channel Port:	Composite Group Flashing (2+1)
North Cardinal Mark:	Very quick or quick
East Cardinal Mark:	Very quick (3) every 5 seconds or quick (3) every 10 seconds
South Cardinal Mark:	Very quick (6) + long flash every 10 seconds or quick (6) + long flash every 15 seconds
West Cardinal Mark:	Very quick (9) every 10 seconds or quick (9) every 15 seconds
Isolated Danger Mark:	Group flashing (2)
Safe Water Mark:	Isophase, occulting, one long flash every 10 seconds or Morse Code "A"
Special Marks:	Any, other than those described for Cardinal, Isolated Danger or Safe Water Marks

SWITCH		IR Controller	FLASH CODE	ON	OFF
A	B				
0	0	0	F (Steady light)		
D	3	211	VQ 0.5 S	0.2	0.3
E	3	227	VQ 0.6 S	0.2	0.4
F	3	243	VQ 0.6 S	0.3	0.3
7	3	115	Q 1 S	0.2	0.8
8	3	131	Q 1 S	0.3	0.7
9	3	147	Q 1 S	0.4	0.6
A	3	163	Q 1 S	0.5	0.5
8	4	132	Q 1 S	0.8	0.2
B	3	179	Q 1.2 S	0.3	0.9
9	4	148	Q 1.2 S	0.5	0.7
C	3	195	Q 1.2 S	0.6	0.6
F	4	244	FL 1.5 S	0.2	1.3
1	0	16	FL 1.5 S	0.3	1.2
0	5	5	FL 1.5 S	0.4	1.1
0	4	4	FL 1.5 S	0.5	1.0
2	0	32	FL 2 S	0.2	1.8
3	0	48	FL 2 S	0.3	1.7
4	0	64	FL 2 S	0.4	1.6
5	0	80	FL 2 S	0.5	1.5
6	0	96	FL 2 S	0.7	1.3
7	0	112	FL 2 S	0.8	1.2
1	2	18	ISO 2 S	1.0	1.0
8	0	128	FL 2.5 S	0.3	2.2
9	0	144	FL 2.5 S	0.5	2.0
D	6	214	FL 2.5 S	1.0	1.5
1	5	21	FL 3 S	0.2	2.8
A	0	160	FL 3 S	0.3	2.7
2	5	37	FL 3 S	0.4	2.6
B	0	176	FL 3 S	0.5	2.5
3	5	53	FL 3 S	0.6	2.4
C	0	192	FL 3 S	0.7	2.3
D	0	208	FL 3 S	1.0	2.0
2	2	34	ISO 3 S	1.5	1.5
5	4	84	OC 3 S	2.0	1.0
E	2	226	OC 3 S	2.5	0.5
4	6	70	OC 3.5 S	2.5	1.0
4	5	69	FL 4 S	0.2	3.8
5	5	85	FL 4 S	0.3	3.7
E	0	224	FL 4 S	0.4	3.6
F	0	240	FL 4 S	0.5	3.5
6	5	101	FL 4 S	0.6	3.4
0	1	1	FL 4 S	0.8	3.2
1	1	17	FL 4 S	1.0	3.0
2	1	33	FL 4 S	1.5	2.5
3	2	50	ISO 4 S	2.0	2.0
3	6	54	OC 4 S	2.5	1.5
F	2	242	OC 4 S	3.0	1.0
3	1	49	FL 4.3 S	1.3	3.0
8	5	133	FL 5 S	0.2	4.8
4	1	65	FL 5 S	0.3	4.7
5	1	81	FL 5 S	0.5	4.5
9	5	149	FL 5 S	0.9	4.1
6	1	97	FL 5 S	1.0	4.0

SWITCH		IR Controller	FLASH CODE	ON	OFF
A	B				
7	1	113	FL 5 S	1.5	3.5
4	2	66	ISO 5 S	2.5	2.5
8	2	130	LFL 5 S	2.0	3.0
0	3	3	OC 5 S	3.0	2.0
1	3	19	OC 5 S	4.0	1.0
2	3	35	OC 5 S	4.5	0.5
C	6	198	FL 6 S	0.2	5.8
B	5	181	FL 6 S	0.3	5.7
C	5	197	FL 6 S	0.4	5.6
8	1	129	FL 6 S	0.5	5.5
9	1	145	FL 6 S	0.6	5.4
A	1	161	FL 6 S	1.0	5.0
7	5	117	FL 6 S	1.2	4.8
B	1	177	FL 6 S	1.5	4.5
5	2	82	ISO 6 S	3.0	3.0
9	2	146	LFL 6 S	2.0	4.0
6	4	100	OC 6 S	4.0	2.0
3	3	51	OC 6 S	4.5	1.5
4	3	67	OC 6 S	5.0	1.0
A	4	164	FL 7 S	1.0	6.0
9	6	150	FL 7 S	2.0	5.0
5	6	86	OC 7 S	4.5	2.5
D	5	213	FL 7.5 S	0.5	7.0
C	1	193	FL 7.5 S	0.8	6.7
E	5	229	FL 8 S	0.5	7.5
B	4	180	FL 8 S	1.0	7.0
6	2	98	ISO 8 S	4.0	4.0
A	2	162	LFL 8 S	2.0	6.0
6	6	102	OC 8 S	5.0	3.0
B	2	178	LFL 8 S	3.0	5.0
F	5	245	FL 9 S	0.9	8.1
C	4	196	FL 9 S	1.0	8.0
7	6	118	OC 9 S	6.0	3.0
0	6	6	FL 10 S	0.2	9.8
1	6	22	FL 10 S	0.3	9.7
D	1	209	FL 10 S	0.5	9.5
2	6	38	FL 10 S	0.8	9.2
E	1	225	FL 10 S	1.0	9.0
1	4	20	FL 10 S	1.5	8.5
C	2	194	LFL 10 S	2.0	8.0
D	2	210	LFL 10 S	3.0	7.0
7	2	114	ISO 10 S	5.0	5.0
2	4	36	LFL 10 S	4.0	6.0
8	6	134	OC 10 S	6.0	4.0
5	3	83	OC 10 S	7.0	3.0
6	3	99	OC 10 S	7.5	2.5
F	1	241	FL 12 S	1.2	10.8
D	4	212	FL 12 S	2.5	9.5
3	4	52	LFL 12 S	2.0	10.0
0	2	2	FL 15 S	1.0	14.0
4	4	68	LFL 15 S	4.0	11.0
7	4	116	OC 15 S	10	5.0
A	6	166	LFL 20 S	2.0	18.0
E	4	228	FL 26 S	1.0	25.0

SWITCH		IR Controller		FLASH CODE	ON	OFF	ON	OFF
A	B							
0	A	10	FL (2) 4 S	0.5	1.0	0.5	2.0	
E	B	235	VQ (2) 4 S	0.2	1.0	0.2	2.6	
1	A	26	FL (2) 4.5 S	0.3	1.0	0.3	2.9	
2	A	42	FL (2) 4.5 S	0.4	1.0	0.4	2.7	
3	A	58	FL (2) 4.5 S	0.5	1.0	0.5	2.5	
F	9	249	FL (2) 5 S	0.2	0.8	0.2	3.8	
2	C	44	FL (2) 5 S	0.2	1.2	0.2	3.4	
4	A	74	FL (2) 5 S	0.4	0.6	0.4	3.6	
0	7	7	FL (2) 5 S	0.5	1.0	0.5	3.0	
1	7	23	FL (2) 5 S	1.0	1.0	1.0	2.0	
9	B	155	Q (2) 5 S	0.3	0.7	0.3	3.7	
2	9	41	Q (2) 5 S	0.5	0.5	0.5	3.5	
5	A	90	FL (2) 5.5 S	0.4	1.4	0.4	3.3	
7	8	120	FL (2) 6 S	0.3	0.6	1.0	4.1	
A	A	170	FL (2) 6 S	0.3	0.9	0.3	4.5	
6	A	106	FL (2) 6 S	0.3	1.0	0.3	4.4	
7	A	122	FL (2) 6 S	0.4	1.0	0.4	4.2	
9	9	153	FL (2) 6 S	0.5	1.0	0.5	4.0	
2	8	40	FL (2) 6 S	0.8	1.2	0.8	3.2	
3	7	55	FL (2) 6 S	1.0	1.0	1.0	3.0	
3	9	57	Q (2) 6 S	0.3	0.7	0.3	4.7	
A	9	169	FL (2) 7 S	1.0	1.0	1.0	4.0	
7	B	123	FL (2) 8 S	0.4	0.6	2.0	5.0	
8	A	138	FL (2) 8 S	0.4	1.0	0.4	6.2	
4	7	71	FL (2) 8 S	0.5	1.0	0.5	6.0	
8	8	136	FL (2) 8 S	0.8	1.2	2.4	3.6	
5	7	87	FL (2) 8 S	1.0	1.0	1.0	5.0	
4	C	76	OC (2) 8 S	3.0	2.0	1.0	2.0	
5	C	92	OC (2) 8 S	5.0	1.0	1.0	1.0	
F	B	251	VQ (2) 8 S	0.2	1.0	0.2	6.6	
9	A	154	FL (2) 10 S	0.4	1.6	0.4	7.6	
6	7	103	FL (2) 10 S	0.5	1.0	0.5	8.0	
7	7	119	FL (2) 10 S	0.5	1.5	0.5	7.5	
6	9	105	FL (2) 10 S	0.5	2.0	0.5	7.0	
8	7	135	FL (2) 10 S	0.8	1.2	0.8	7.2	
B	9	185	FL (2) 10 S	1.0	1.0	1.0	7.0	
9	7	151	FL (2) 10 S	1.0	1.5	1.0	6.5	
4	9	73	Q (2) 10 S	0.6	0.4	0.6	8.4	
B	A	186	FL (2) 12 S	0.4	1.0	0.4	10.2	
C	9	201	FL (2) 12 S	0.5	1.0	0.5	10.0	
D	9	217	FL (2) 12 S	1.5	2.0	1.5	7.0	
A	8	168	FL (2) 15 S	0.5	1.5	2.0	11.0	
A	7	167	FL (2) 15 S	1.0	2.0	1.0	11.0	
8	B	139	Q (2) 15 S	0.2	0.8	0.2	13.8	
C	A	202	FL (2) 20 S	1.0	3.0	1.0	15.0	
D	A	218	FL (2) 25 S	1.0	1.0	1.0	22.0	

SWITCH		IR Controller		FLASH CODE	ON	OFF	ON	OFF	ON	OFF
A	B									
7	9	121	Q (3) 5 S	0.5	0.5	0.5	0.5	0.5	2.5	
5	9	89	VQ (3) 5 S	0.2	0.3	0.2	0.3	0.2	3.8	
0	C	12	VQ (3) 5 S	0.3	0.2	0.3	0.2	0.3	3.7	
E	9	233	VQ (3) 5 S	0.3	0.3	0.3	0.3	0.3	3.5	
3	C	60	FL (3) 6 S	0.5	1.0	0.5	1.0	0.5	2.5	
2	B	43	FL (2+1) 6 S	0.3	0.4	0.3	1.2	0.3	3.5	

SWITCH		IR Controller	FLASH CODE	ON	OFF	ON	OFF	ON	OFF
A	B								
A	B	171	Q (3) 6 S	0.3	0.7	0.3	0.7	0.3	3.7
F	A	250	FL (3) 8 S	0.5	1.0	0.5	1.0	0.5	4.5
0	B	11	FL (3) 9 S	0.3	1.0	0.3	1.0	0.3	6.1
B	7	183	FL (3) 9 S	0.8	1.2	0.8	1.2	0.8	4.2
B	8	184	FL (3) 10 S	0.3	0.7	0.3	0.7	0.9	7.1
C	8	200	FL (3) 10 S	0.4	0.6	0.4	0.6	1.2	6.8
C	B	203	FL (3) 10 S	0.5	0.5	0.5	0.5	0.5	7.5
C	7	199	FL (3) 10 S	0.5	1.5	0.5	1.5	0.5	5.5
D	B	219	FL (3) 10 S	0.6	0.6	0.6	0.6	0.6	7.0
D	7	215	FL (3) 10 S	1.0	1.0	1.0	1.0	1.0	5.0
3	8	56	FL (2+1) 10 S	0.5	0.7	0.5	2.1	0.5	5.7
8	9	137	OC (3) 10 S	5.0	1.0	1.0	1.0	1.0	1.0
B	B	187	Q (3) 10 S	0.3	0.7	0.3	0.7	0.3	7.7
D	8	216	FL (2 + 1) 10 S	0.5	0.5	0.5	0.5	1.5	6.5
1	B	27	FL (3) 12 S	0.5	1.5	0.5	1.5	0.5	7.5
E	A	234	FL (3) 12 S	0.5	2.0	0.5	2.0	0.5	6.5
E	7	231	FL (3) 12 S	0.8	1.2	0.8	1.2	0.8	7.2
B	6	182	FL (3) 12 S	1.0	1.0	1.0	3.0	1.0	5.0
4	8	72	FL (2+1) 12 S	0.8	1.2	0.8	2.4	0.8	6.0
5	8	88	FL (2+1) 12 S	1.0	1.0	1.0	4.0	1.0	4.0
1	8	24	FL (2+1) 13.5 S	1.0	1.0	1.0	4.0	1.0	5.5
F	7	247	FL (3) 15 S	0.3	1.7	0.3	1.7	0.3	10.7
9	D	157	FL (3) 15 S	0.4	1.0	0.4	1.0	0.4	11.8
0	8	8	FL (3) 15 S	0.5	1.5	0.5	1.5	0.5	10.5
F	8	248	FL (2+1) 15 S	0.6	0.3	0.6	0.3	1.4	11.8
0	9	9	FL (2+1) 15 S	0.7	0.5	0.7	0.5	1.9	10.7
1	9	25	FL (2+1) 15 S	0.7	0.7	0.7	0.7	2.1	10.1
6	8	104	FL (2+1) 15 S	1.0	2.0	1.0	5.0	1.0	5.0
1	C	28	VQ (3) 15 S	0.1	0.5	0.1	0.5	0.1	13.7
4	B	75	FL (3) 20 S	0.5	3.0	0.5	3.0	0.5	12.5
3	B	59	FL (3) 20 S	0.5	1.5	0.5	1.5	0.5	15.5
5	B	91	FL (3) 20 S	0.8	1.2	0.8	1.2	0.8	15.2
6	B	107	FL (3) 20 S	1.0	1.0	1.0	1.0	1.0	15.0

SWITCH		IR Controller	FLASH CODE	ON	OFF	ON	OFF	ON	OFF	ON	OFF
A	B										
B	F	191	VQ (4) 4 S	0.3	0.3	0.3	0.3	0.3	0.3	0.3	2.3
B	D	189	Q (4) 6 S	0.3	0.7	0.3	0.7	0.3	0.7	0.3	2.7
8	D	141	Q (4) 6 S	0.4	0.6	0.4	0.6	0.4	0.6	0.4	2.6
1	D	29	FL (4) 10 S	0.5	1.0	0.5	1.0	0.5	1.0	0.5	5.0
2	D	45	FL (4) 10 S	0.8	1.2	0.8	1.2	0.8	1.2	0.8	3.2
F	E	254	Q (4) 10 S	0.3	0.7	0.3	0.7	0.3	0.7	0.3	6.7
B	E	190	FL (4) 12 S	0.3	1.7	0.3	1.7	0.3	1.7	0.3	5.7
4	F	79	FL (4) 12 S	0.5	0.5	0.5	0.5	0.5	0.5	0.5	8.5
C	E	206	FL (4) 12 S	0.5	1.5	0.5	1.5	0.5	1.5	0.5	5.5
3	D	61	FL (4) 12 S	0.8	1.2	0.8	1.2	0.8	1.2	0.8	5.2
A	D	173	Q (4) 12 S	0.3	0.7	0.3	0.7	0.3	0.7	0.3	8.7
4	D	77	FL (4) 15 S	0.5	1.5	0.5	1.5	0.5	1.5	0.5	8.5
8	E	142	FL (4) 15 S	1.0	1.0	1.0	1.0	1.0	1.0	1.0	8.0
7	D	125	FL (4) 15 S	1.5	0.5	0.5	0.5	0.5	0.5	0.5	10.5
D	E	222	FL (4) 16 S	0.5	1.5	0.5	1.5	0.5	1.5	0.5	9.5
C	D	205	FL (4) 20 S	0.3	3.0	0.3	3.0	0.3	3.0	0.3	9.8
5	D	93	FL (4) 20 S	0.5	1.5	0.5	1.5	0.5	1.5	0.5	13.5
0	D	13	FL (4) 20 S	0.5	1.5	0.5	1.5	0.5	4.5	0.5	10.5
3	F	63	FL (4) 20 S	1.5	1.5	1.5	1.5	1.5	1.5	1.5	9.5
0	F	15	Q (4) 20 S	0.5	0.5	0.5	0.5	0.5	0.5	0.5	16.5
E	E	238	Q (4) 28 S	0.5	0.5	0.5	0.5	0.5	0.5	0.5	24.5
6	F	111	FL (4) 30 S	0.5	0.5	0.5	0.5	0.5	0.5	0.5	26.5

SWITCH		IR											
A	B	Controller	FLASH CODE	ON	OFF	ON	OFF	ON	OFF	ON	OFF	ON	OFF
D	D	221	Q (5) 7 S	0.3	0.7	0.3	0.7	0.3	0.7	0.3	0.7	0.3	0.7
E	D	237	Q (5) 10 S	0.3	0.7	0.3	0.7	0.3	0.7	0.3	0.7	0.3	0.7
E	8	232	FL (5) 12 S	0.5	1.5	0.5	1.5	0.5	1.5	0.5	1.5	0.5	1.5
5	F	95	FL (5) 20 S	0.5	0.5	0.5	0.5	0.5	0.5	0.5	0.5	0.5	0.5
9	F	159	FL (5) 20 S	0.8	1.2	0.8	1.2	0.8	1.2	0.8	1.2	0.8	1.2
9	E	158	FL (5) 20 S	1.0	1.0	1.0	1.0	1.0	1.0	1.0	1.0	1.0	1.0

SWITCH		IR													
A	B	Controller	FLASH CODE	ON	OFF	ON	OFF	ON	OFF	ON	OFF	ON	OFF	ON	OFF
F	D	253	Q (6) 10 S	0.3	0.7	0.3	0.7	0.3	0.7	0.3	0.7	0.3	0.7	0.3	0.7
A	F	175	FL (6) 15 S	0.3	0.7	0.3	0.7	0.3	0.7	0.3	0.7	0.3	0.7	0.3	0.7
7	F	127	FL (6) 15 S	0.5	1.0	0.5	1.0	0.5	1.0	0.5	1.0	0.5	1.0	0.5	1.0

SWITCH		IR															
A	B	Controller	FLASH CODE	ON	OFF	ON	OFF	ON	OFF	ON	OFF	ON	OFF	ON	OFF	ON	OFF
6	E	110	VQ (6) + LFL 10 S	0.2	0.3	0.2	0.3	0.2	0.3	0.2	0.3	0.2	0.3	0.2	0.3	0.2	0.3
7	E	126	VQ (6) + LFL 10 S	0.3	0.3	0.3	0.3	0.3	0.3	0.3	0.3	0.3	0.3	0.3	0.3	0.3	0.3
2	F	47	Q (6) + LFL 15 S	0.2	0.8	0.2	0.8	0.2	0.8	0.2	0.8	0.2	0.8	0.2	0.8	0.2	0.8
2	E	46	Q (6) + LFL 15 S	0.3	0.7	0.3	0.7	0.3	0.7	0.3	0.7	0.3	0.7	0.3	0.7	0.3	0.7
3	E	62	Q (6) + LFL 15 S	0.6	0.6	0.6	0.6	0.6	0.6	0.6	0.6	0.6	0.6	0.6	0.6	0.6	0.6
8	F	143	VQ (6) + LFL 15 S	0.3	0.3	0.3	0.3	0.3	0.3	0.3	0.3	0.3	0.3	0.3	0.3	0.3	0.3

SWITCH		IR																	
A	B	Controller	FLASH CODE	ON	OFF	ON	OFF	ON	OFF	ON	OFF	ON	OFF	ON	OFF	ON	OFF	ON	OFF
4	E	78	VQ (9) 10 S	0.2	0.3	0.2	0.3	0.2	0.3	0.2	0.3	0.2	0.3	0.2	0.3	0.2	0.3	0.2	0.3
5	E	94	VQ (9) 10 S	0.3	0.3	0.3	0.3	0.3	0.3	0.3	0.3	0.3	0.3	0.3	0.3	0.3	0.3	0.3	0.3
1	F	31	Q (9) 15 S	0.2	0.8	0.2	0.8	0.2	0.8	0.2	0.8	0.2	0.8	0.2	0.8	0.2	0.8	0.2	0.8
0	E	14	Q (9) 15 S	0.3	0.7	0.3	0.7	0.3	0.7	0.3	0.7	0.3	0.7	0.3	0.7	0.3	0.7	0.3	0.7
1	E	30	Q (9) 15 S	0.6	0.6	0.6	0.6	0.6	0.6	0.6	0.6	0.6	0.6	0.6	0.6	0.6	0.6	0.6	0.6

SWITCH		IR										
A	B	Controller	FLASH CODE	ON	OFF	ON	OFF	ON	OFF	ON	OFF	
MORSE CODE () INDICATES LETTER												
7	8	120	MO (A) 6 S	0.3	0.6	1.0	4.1					
7	B	123	MO (A) 8 S	0.4	0.6	2.0	5.0					
8	8	136	MO (A) 8 S	0.8	1.2	2.4	3.6					
B	8	184	MO (U) 10 S	0.3	0.7	0.3	0.7	0.9	7.1			
C	8	200	MO (U) 10 S	0.4	0.6	0.4	0.6	1.2	6.8			
D	8	216	MO (U) 10 S	0.5	0.5	0.5	0.5	1.5	6.5			
9	8	152	MO (A) 10 S	0.5	0.5	1.5	7.5					
8	9	137	MO (D) 10 S	5.0	1.0	1.0	1.0	1.0	1.0			
A	8	168	MO (A) 15 S	0.5	1.5	2.0	11.0					
F	8	248	MO (U) 15 S	0.6	0.3	0.6	0.3	1.4	11.8			
0	9	9	MO (U) 15 S	0.7	0.5	0.7	0.5	1.9	10.7			
1	9	25	MO (U) 15 S	0.7	0.7	0.7	0.7	2.1	10.1			
7	D	125	MO (B) 15 S	1.5	0.5	0.5	0.5	0.5	0.5	0.5	10.5	



GPS Synchronisation

SL-07, SL-C310 & SL-C410 Models

The SL-07, SL-C310 and SL-C410 models come with GPS fitted as standard, and provide the user with the ability to install independently operating lanterns that all flash in synchronisation.

No additional power supplies, aerials or control systems are required, and with its microprocessor-based system, the GPS option is specifically designed to provide maximum reliability and performance over a wide range of environmental conditions.

Operating Principle

Each light operates independently and requires no operator intervention. A minimum of 4 satellites need to be in view for the built-in GPS receiver to collect time data. At dusk, the light sensor will turn the light on. If time data is available the light will come on synchronised to every other light with the same selected flash code.

Synchronisation is achieved using an internal algorithm based on the highly accurate time base and time data received from the satellites. The satellite data is provided from a number of earth stations using atomic clocks as the time base. Continuous self-checking ensures that the light will continue to run in synchronisation.

Light Activation

At power-up the microprocessor checks that the internal GPS module is programmed correctly and is able to provide valid time base and time data.

Once outside with a clear view of the sky, valid data should become available within 20 minutes.

Daylight Operation

During daylight hours the microprocessor is in idle mode to reduce power consumption. Time data continues to be updated once per second. The microprocessor will automatically exit the idle mode as soon as dark conditions are detected.

Dark Operation

When dark conditions are detected the light:

- Checks for valid time data and is turned on after a delay based on the current time and the length of the selected flash code;
- If valid time data is not detected the light will turn on after approximately 10 seconds. This light will not be synchronised.
- If the light turns on unsynchronised it will continually check for valid time data. Once valid data is found the light will automatically synchronise.

Note: Lights will not synchronise if different flash codes are selected.

GPS Power Demand

The GPS synchronisation feature has been designed to function with a very low power demand. Typically the total 24hr current used by the GPS module is 36mAh. This is approximately equivalent to 8 minutes of solar charging.

Note: To disable GPS synchronisation refer to **GPS Synchronisation Control and Status** in the **IR Controller Functions** section of this manual.

Lantern Status

Two status LED's on the main printed circuit board provide the operator with an indication of the lantern status.

There is one red and one yellow status LED. The red status LED is used to indicate the health of the lantern's power system. The yellow status LED is used to indicate the operational status of the lantern.

These indicator LED's can be viewed at the base of the lens.

All Sealite boards are fitted with two Indicator LED's. These are positioned near the Flash Code Rotary Switches. Use the table below to help determine operational status.

Yellow LED	Lantern Status	Lantern	Comment
OFF	Normal	OFF	Lantern is in Daylight and in Dusk till Dawn mode or in Standby Mode
Flashing ON 0.15 seconds OFF 0.15 seconds	Normal	OFF	Light is activating and will turn on after detecting 30 seconds of continuous darkness.
Flashing 2 x quick flashes every 2 seconds (Heartbeat)	Normal	ON	Lantern is in Normal operating condition. It is not connected to any GPS synchronisation.
Flashing ON 1.5 seconds OFF 1.5 seconds	Normal	ON	Normal operating condition. Lantern is synchronised to GPS-enabled lanterns.
Flashing 1 x quick flash every 2 seconds	Normal	ON	Lantern is 're-syncing' with GPS. The lantern re-sync's with the GPS every 15 minutes.
Flashing 2 x quick flashes every 11 seconds	Normal	ON	Lantern is a Hard Wire Synchronisation Slave.

Red LED	Lantern Status	Lantern	Comment
OFF	Normal		Normal Battery Voltage
Flashing once every 1.6 seconds	Battery Voltage is 12 – 12.5V		Battery Voltage is between 12 – 12.5V
Flashing twice every 2 seconds	Battery Voltage is 11.5 – 12V		Battery Voltage is between 11.5 – 12V
Flashing 3 x times every 2 seconds	Battery Voltage is 10.0 – 11.5V		Battery Voltage is between 10.0 – 11.5V
Flashing 4 x times every 2.5 seconds	Battery Voltage is less than 10.0V		Battery Voltage is at less than 10.0V
Fixed-on	Flat Battery (<10V)	OFF	Flat Battery cut-off is now operational and the lantern will be off. Battery must receive charge (above 12V) and lantern must see daylight for at least 1 minute before resuming normal operation.
Flashing ON 1.5 seconds OFF 1.5 seconds	Battery Voltage is above 13.5V		Battery Voltage is above 13.5V. this may indicate a problem with the solar regulator.

Optional IR Remote Control

SL-07, SL-C310 & SL-C410 Models

The IR remote is used to communicate with Sealite lighting products that have an IR sensor fitted. The remote control is used for the following functions:

- Flash Code: read the current flash code, configure a new flash code.
- Lamp Intensity: read the current lamp intensity, configure a new intensity level.
- Ambient Light Thresholds: read the current light thresholds, configure new ambient light thresholds.
- Perform a battery health check.

On receiving a valid key signal from the IR Remote, the light will flash once.

The user should wait until the light responds to each keypress before pressing another key. If there is no response to the keypress after 3 seconds, it has not been detected by the light and the key can be pressed again.

If an invalid key is detected, the light will flash quickly 5 times. In this case, the command will have to be restarted.

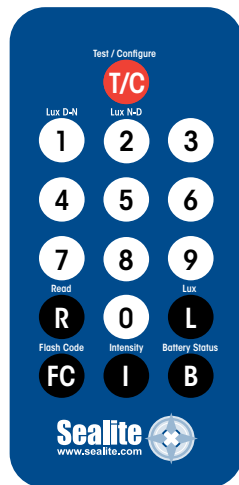

Sealite IR Controller / Universal Remote Compatibility

If you lose your Sealite IR Controller, the following Universal Remote Controller has been tested for compatibility: RCA Type RCR312WR programmed for Phillips TV Type Code 10054

Sealite Key	Universal Remote Key
T	Power
1	1
2	2
3	3
4	4
5	5
6	6
7	7
8	8
9	9
0	0
R	Channel+
L	Mute
FC	Volume+
I	Volume-
B	Channel-



IR Controller Functions

Test Mode / Configure



Pressing the T/C button for upto 5 seconds places the light in Test Mode. The light will flash once in response to the T/C button being pressed and then turn off.



Normal Operation



The light will return to normal operation once it has not detected a valid key press for 30 seconds. The light will flash once to indicate it is returning to normal operation.



Read



Pressing the Read followed by one of the configuration keys shall cause the light to flash the configured value.

Example Key Sequences:

   The light flashes the 'IR Remote' number belonging to the currently set Flash Code. Refer to the Flash Code tables to match the 'IR Remote' flash number to the Flash Code.

   The light flashes the current intensity setting: 1 flash for 25%, 2 for 50%, 3 for 75% and 4 for 100%.

   The light flashes the current battery status.

   The light flashes the sunset level in Lux, followed by a 2 second gap, followed by the sunrise level. Levels are in the range of 1 to 9.



Flash Code

FC

This key sets the flash code on the light.

Example Key sequence:



This sets the flash code to value 123. The light responds by flashing the flash code value.

Flash Code Numbers

The lamp flashes numbers as follows: Hundreds, Tens, Ones. A value of 125 will be flashed as: 1 flash, followed by a delay, 2 flashes, followed by a delay, 5 flashes.

The flash for number 0 is one long flash.

For example if the current Flash Code is set to 51 via the AB switches, the lamp will flash number 081. For a flash code set to 01, the lamp will flash 001.

Intensity

This function sets the light intensity. Valid intensity values are 1 for 25%, 2 for 50%, 3 for 75% and 4 for 100%.

I

Example Key sequence:



This sets the light intensity to 25%.

Battery Status

B

This function reads the battery status. The response from the light is High Voltage: 4 flashes, Good Voltage: 3 flashes, Low Voltage 2 flashes, Cutoff Voltage or below: 1 flash.

Example Key sequence:



Lux



This key sets the ambient light threshold levels.

The format is



Where 'x' is the desired setting from the table below.

There are 5 programmable lux levels which are set together for the sunset and sunrise transitions.

Level	Sunset (Dusk)	Sunrise (Dawn)
1	64	100
2*	100	150
3	150	240
4	240	370
5	370	600
* Default / Factory Preset		

Example key sequence:



Assume the current Lux settings are at the factory preset values of 2.

This sets the ambient light level to be lower than the default 100 lux. The light will turn on when its surroundings are darker.

The light responds by acknowledgement with a long flash.



Error / Acknowledge Indication

If the key sequence is invalid, or an out of bounds value is attempted to be set, the light flashes 5 times for 1 second. (The command then needs to be sent from the start.)

Example key sequence: (Set the intensity level to 5 – undefined.)



The light flashes 5 times for 1 second.

When a key sequence has been entered successfully the light will respond acknowledgement with a long 1 second flash.

Configuration Settings

The intensity and flash codes can be changed using the switches on the lamp circuit board or with the IR Remote Control. The lamp intensity and flash code settings are set to the last detected change, carried out with the IR Remote Control or by changing the switch positions.

Example #1: If the intensity is set at 100% with the intensity switches, and is then set to 50% using the IR Remote Control, the intensity setting will change to 50%. If the intensity is then set to 75% using the switches, the new intensity value will be 75%.

In order to change intensity settings using the IR Remoter Control, the lamp must be powered.

The lamp can detect a change in switch settings if they are changed while the light is powered down.

Example #2: The flash code is set according to the switch settings: A=5, B = 1. The operator changes the flash code to 65 (A=4, B=1) using the IR Remote Control. The new flash code is now configured to A=4, B=1. The lamp is powered down and the operator changes the flash code switches to A=3, B=1 and powers on the light. The new flash code is now A=3, B=1. If the flash code is read from the light using the IR Remote Control, the lamp will flash 49 which is the corresponding number for switches A=3, B=1.

Use the IR Remote Control to read the current lamp intensity setting and flash code.

Hibernation Mode (Advanced users)



For situations where the lantern is put into storage for a known period, the IR Remote control can be used to configure the lantern into Hibernation Mode for a user programmable date range.

Hibernation Mode maximises conservation of the battery power by disabling the light (will not activate at night) and shutting off the GPS receiver to rely on the internal clock for date checking. The IR sensor is still monitored in hibernation mode. Power consumption is only bettered by physically disconnecting the battery supply.

Hibernation Mode is defined by a start date and end date that are programmed into the lantern via the IR Remote Control.

Using the IR Remote Control

The lantern must be in Test Mode prior to pressing any of the following key sequences. However, the lantern will return to Normal Operation if it has not detected a valid key press for a period of 15 seconds. When the lantern exits from Test Mode it will either enter Dusk to Dawn mode, Hibernation mode, or Storage Mode, if enabled.

Store Hibernation Mode Date Range

The following details the key press sequence that defines the start and end dates of Hibernation Mode:



where **ddmm** is the numerical representation of the month (01=January, 08=August) of the start date, and **DDMM** is the numerical representation of the end date.

e.g 9th of December is represented by the number sequence 0912.

The lantern will respond by flashing an acknowledge long flash.

This operation only stores the start & end dates into the lantern's memory and Hibernation Mode still must be enabled to commence its operation.

Enable Hibernation Mode

Pressing the following key sequence will enable (turn on) Hibernation Mode:



and the lantern will respond with a single flash.

The Lantern will take a new GPS reading, determine the calendar month, and then enter Hibernation Mode and depending on the current calendar month setting will either Hibernate or enter Dusk-to-Dawn mode.

By default, Hibernation mode is disabled. Note you can only use this command once a valid hibernation start & end date has been stored in the lantern.

Disable Hibernation / Hibernation Modes

Pressing the following key sequence will disable (turn off) both Hibernation Mode and Seasonal Hibernation:



and the lantern will respond with a single long flash.

The Lantern will disable Hibernation Mode and enter Dusk-to-Dawn Mode.

Momentarily Wake Up from Hibernation Mode

Pressing the **T/C** button will wake up the lantern.

At which point the lantern will remain awake for a further 15 seconds to process other commands from the IR Controller. If no IR commands are received for a period of 15 seconds, the lantern will return to Hibernation mode.

Read Stored Hibernation Dates

By pressing the following key sequence the lantern will respond with the stored start and end dates for Hibernation:



Read Hibernation Mode Status

By pressing the following key sequence the lantern will respond with status of Hibernation mode.



Where:

- A single long flash = hibernation mode is Enabled
- Two quick flashes = hibernation mode is Disabled.

User Case Example: Configuring the lantern for Hibernation

In this example, we want the lantern to hibernate each year from Dec 10th, through to February 15th, and the lantern is located inside a storage warehouse.

The required key sequence is:

Command	IR Controller Key Press
Store the Hibernation Date Range	L I 1 0 1 2 1 5 0 2 T/C
Enable Hibernation	L I 1 T/C

Storage Mode (Advanced users)

For situations where the lantern is put into storage but with access to daylight, the IR Remote control can be used to configure the lantern into Storage Mode.

This mode manually forces the lantern to turn off, but with access to daylight it will still charge battery pack. However the lantern will not keep track of the date.

In Storage Mode, the GPS is disabled however the lantern will still respond to IR commands.

The lantern will automatically enter Storage Mode, if it is hibernating and it has not detected any light for 20 hours.

Enter Storage Mode

By pressing the following key sequence the lantern will enter Storage Mode:



The lantern will leave storage mode when exposed to daylight or if the power switch is turned OFF and ON again.

Optional GSM Monitoring & Control System

SL-C410 Model

The SL-C410 may also be fitted with GSM Cell-Phone Monitoring and Control – enabling users to access real-time diagnostics data and change lantern settings via cell-phone. The system can also be configured to send out alarm SMS text messages to designated cellular telephone numbers. users can also have alarms and reports sent to designated email addresses.

Please contact Sealite for further information and instructions.

Maintenance & Servicing

SL-07 Model

Designed to be maintenance free, the SL-07 requires minimal attention, though the following maintenance and servicing information is provided to help ensure the life of your product.

1. **Cleaning Lens-** occasional cleaning of the light lens may be required. Using a cloth and warm soapy water, wipe off any foreign matter before rinsing the lens with fresh water.
2. **Battery Check-** inspection of batteries should be performed every three years (minimum) to ensure that the charger, battery and ancillary electronics are functioning correctly. Using a voltage meter, check that the battery voltage is at least 12 volts under 100mA load, and ensure all terminals are clear of foreign matter (Battery Connected Units Only).



SL-C310 & SL-C410 Models

Designed to be almost maintenance-free, the SL310 and SL-C410 require minimal attention, though the following maintenance and servicing information is provided to help ensure the life of your Sealite product.

1. **Cleaning Solar Panels-** occasional cleaning of the solar panels may be required. Using a cloth and warm soapy water, wipe off any foreign matter before rinsing the panels with fresh water.
2. **Battery Check-** inspection of batteries should be performed every three years (minimum) to ensure that the charger, battery and ancillary electronics are functioning correctly. Using a voltage meter, check that the battery voltage is at least 12 volts under 100mA load, and ensure all terminals are clear of foreign matter.
3. **O-Ring Check-** inspect the condition of the o-ring for damage, wear or if it is brittle, and replace if necessary. The o-ring should be a rubber texture to ensure a complete and even seal.

Replacing the Battery

The SL-C310 and SL-C410 have an internal battery compartment, which provides the user with the ability to change the battery after years of operation.

1. Remove the four socket-head screws on the top lens assembly and separate the SL-C310/410 lens assembly from the body/base section.
2. Remove 2 x M4 cap screws & washers from the top of the chassis.
3. Disconnect the light head and battery via the 4Pin connector.
4. Lift the upper battery bracket out of the SL-C310/410.
5. Remove the old battery from the chassis.
6. Contact Sealite if you require a battery.
7. Discard old battery in a safe manner.
8. Reconnect the new battery.
9. Place battery back inside lantern body, and position the upper battery bracket in the top of the chassis.
10. Secure using 2 x M4 cap screws & washers.
11. Feed all wiring back inside lantern body, and make sure the o-ring is properly placed at the top of the lantern body. Reconnect the 4 pin connector.
12. Place the top lens assembly back onto the lantern body and replace 4 socket head screws. Half tighten all 4 socket head screws, and then fully tighten each socket head screw to ensure an even seal.
13. To test place dark cover (towel or jacket) on top of light to activate sensor, light will come on.

***Care must be taken to observe the polarity of each wire before they are connected.
To ensure waterproofing of the unit, make sure that there is an even seal.***

Long Term Battery Storage

If the SL-C310/410 is to be placed in storage for an extended period please follow the below information.

The sealed lead acid batteries inside the lights must always be stored in a fully charged state. Always make sure the ON/OFF switch is in the OFF position.

If an ON/OFF switch is not fitted please disconnect the light head from the solar unit.

All batteries will discharge over time and the rate of discharge is dependent on temperature.

If the light is being stored in temperatures greater than 40°C the battery will discharge faster.

Please check battery regularly and recharge if necessary.

Re-connect the light head and battery and place unit in the sun for 2-4 days

Solar Panel Replacement (SL-C310 & SL-C410 Models)

The SL-C310 and SL-C410 are built around an internal aluminium chassis. The solar panels can be user-replaced in the unlikely event that one is broken or damaged during the product's life.

Follow the steps below or contact support@sealite.com for more details.

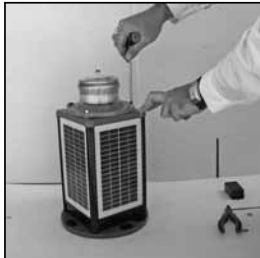

1. Remove 4 x M6 x 20 socket head cap screws and 4 x M6 nylon washers and disconnect the light head from the chassis
2. Remove the 2 x M4 x 20 socket head cap screws, 2 x M4 spring washers and 2 x M4 penny washers. Remove the upper battery bracket containing regulator
3. Disconnect the battery



4. Remove 4 x M6 x 35 socket head cap screws, to remove the top casting from the chassis.

Note:

Be careful not to damage the o-rings on each of these screws. If replacements are required please use standard 6x1.0mm o-ring.



5. Slide the rubber corner out of the chassis, it may be necessary to lubricate the edges of the solar panels with grease or oil based lubricant if this is difficult to remove.
6. Unscrew the affected panel wires from the regulator and remove the solar panel from the chassis.

7. Clean any silicon off the chassis from the solar panel junction box hole and add a new seal to ensure the solar panel is watertight when assembled.

8. Repeat the process in the reverse order to replace a new panel.

Note:

Make sure the O-rings on the top casting and 4 x M6 x 35 socket head cap screws are coated in silicon grease before re-assembling.



The replacement of a solar panel should only be performed by a confident technician.

Sealite cannot guarantee the chassis will remain waterproof, if it not performed by Sealite staff.

To test for any leaks remove the gore vent and pressurise the assembled Light to 1.5psi.

How to Change the Regulator (SL-C310 & SL-C410 Models)

1. Remove the 4 x M6 x 20 socket head cap screws and 4 x M6 nylon washers, then disconnect the light head from the chassis.
2. Remove the 2 x M4 x 20 socket head cap screws, 2 x M4 spring washers and 2 x M4 penny washers then remove the upper battery bracket containing the regulator.
3. Disconnect the battery.
4. Take note of the wire colours and location in the regulator.
5. Disconnect the wires from the regulator.
6. Remove the 2 x M4 CSSK screws, 2 x M4 nylock nuts and 2 x M4 penny washers that retain the regulator to the top battery bracket and remove the regulator.
7. Fit the new regulator using the 2 x M4 CSSK screws, 2 x M4 penny washers and 2 x M4 nylock nuts.
8. Connect the solar positive wires to the $\overset{+}{S}$ points on the regulator.
9. Connect the solar negative wires to the \bar{S} points on the regulator.
10. Connect the battery positive wires to the $\overset{+}{B}$ point on the regulator.
11. Connect the battery negative wire to the \bar{B} point on the regulator.
12. Reconnect the battery.
13. Refit the battery top bracket into the solar unit using the 2 x M4 x 20 socket head cap screws.
14. Ensure the top O-ring is sitting correctly into the top casting. Refit the light head and tighten the M6 x 20 socket head cap screws with the 4 x M6 nylon washers evenly. **DO NOT OVERTIGHTEN.**



Use the label to ensure correct location of wires during assembly



SL10 AMP Regulator shown when correctly fitted

Trouble Shooting

SL-07 Model

Problem	Remedy
Lantern will not activate.	<ul style="list-style-type: none"> • Ensure internal toggle switch is set to the 'ON position. • Ensure lantern is in darkness. • Wait at least 60 seconds for the program to initialise in darkness. • Ensure switch setting is on a valid code (not unused flash code). • Ensure battery terminals are properly connected. • Ensure battery voltage is above 12volts.
Timing codes will not change.	<ul style="list-style-type: none"> • Turn rotary switches several times to ensure contacts are clear.
Lantern will not operate for the entire night.	<ul style="list-style-type: none"> • Reducing the light output intensity or duty cycle (flash code) will reduce current draw on the battery.

SL-C310 & SL-C410 Models

Problem	Remedy
Lantern will not activate.	<ul style="list-style-type: none"> • Ensure lantern is in darkness. • Wait at least 60 seconds for the program to initialise in darkness. • Ensure switch setting is on a valid code (not unused flash code). • Ensure battery terminals and light head are properly connected. • Ensure battery voltage is above 12volts. • Check the Status LED's on the base of the PCB to determine what type of fault the light is activating.
Flash Codes will not change.	<ul style="list-style-type: none"> • Turn rotary switches several times to ensure contacts are clear.
Lantern will not operate for the entire night.	<ul style="list-style-type: none"> • Expose lantern to direct sunlight and monitor operation for several days. <i>Sealite products typically require 2.5 hours of direct sunlight per day to retain full autonomy. From a discharged state, the lantern may require several days of operational conditions to 'cycle' up to full autonomy.</i> • Reducing the light output intensity or duty cycle (flash code) will reduce current draw on the battery. • Ensure solar module is clean and not covered by shading during the day.



Sealite LED Light Warranty V2.1

Activating the Warranty

Upon purchase, the Sealite Pty Ltd warranty must be activated for recognition of future claims. To do this you have two (2) options:

1. **Postal Registration** - please complete the Sealite Warranty Registration Card and return to Sealite within 30 days of your purchase.
2. **Online Registration** - please complete the Online Registration Form at; www.sealite.com

Sealite Pty Ltd will repair or replace your LED light in the event of electronic failure for a period of up to three years from the date of purchase.

The unit must be returned to Sealite freight prepaid.

Warranty Terms

1. Sealite Pty Ltd warrants that any Sealite marine products fitted with telemetry equipment including but not limited to AIS, GSM, GPS or RF ("Telemetry Products") will be free from defective materials and workmanship under normal and intended use, subject to the conditions hereinafter set forth, for a period of twelve (12) months from the date of purchase by the original purchaser.
2. Sealite Pty Ltd warrants that any BargeSafe™ Series of LED barge light products ("BargeSafe™ Products") will be free from defective materials and workmanship under normal and intended use, subject to the conditions hereinafter set forth, for a period of twelve (12) months from the date of purchase by the original purchaser.
3. Sealite Pty Ltd warrants that any LED area lighting products ("Area Lighting Products") but not including sign lighting products will be free from defective materials and workmanship under normal and intended use, subject to the conditions hereinafter set forth, for a period of twelve (12) months from the date of purchase by the original purchaser.
4. Sealite Pty Ltd warrants that any LED sign lighting products ("Sign Lighting Products") will be free from defective materials and workmanship under normal and intended use, subject to the conditions hereinafter set forth, for a period of three (3) years from the date of purchase by the original purchaser.
5. Sealite Pty Ltd warrants that any Sealite marine lighting products other than the Telemetry Products, BargeSafe™ Products, and Area Lighting Products ("Sealite Products") will be free from defective materials and workmanship under normal and intended use, subject to the conditions hereinafter set forth, for a period of three (3) years from the date of purchase by the original purchaser.
6. Sealite Pty Ltd will repair or replace, at Sealite's sole discretion, any Telemetry Products, BargeSafe™ Products, Area Lighting Products or Sealite Products found to be defective in material and workmanship in the relevant warranty period so long as the Warranty Conditions (set out below) are satisfied.
7. If any Telemetry Products, BargeSafe™ Products, Area Lighting Products or Sealite Products are fitted with a rechargeable battery, Sealite Pty Ltd warrants the battery will be free from defect for a period of one (1) year when used within original manufacturer's specifications and instructions.

Warranty Conditions

This Warranty is subject to the following conditions and limitations;

1. The warranty is applicable to lanterns manufactured from 1/1/2009.
2. The warranty is void and inapplicable if:
 - a. the product has been used or handled other than in accordance with the instructions in the owner's manual and any other information or instructions provided to the customer by Sealite;
 - b. the product has been deliberately abused, or misused, damaged by accident or neglect or in being transported; or
 - c. the defect is due to the product being repaired or tampered with by anyone other than Sealite or authorised Sealite repair personnel.

3. The customer must give Sealite Pty Ltd notice of any defect with the product within 30 days of the customer becoming aware of the defect.
4. Rechargeable batteries have a limited number of charge cycles and may eventually need to be replaced. Typical battery replacement period is 3-4 years. Long term exposure to high temperatures will shorten the battery life. Batteries used or stored in a manner inconsistent with the manufacturer's specifications and instructions shall not be covered by this warranty.
5. No modifications to the original specifications determined by Sealite shall be made without written approval of Sealite Pty Ltd.
6. Sealite lights can be fitted with 3rd party power supplies and accessories but are covered by the 3rd party warranty terms and conditions.
7. The product must be packed and returned to Sealite Pty Ltd by the customer at his or her sole expense. Sealite Pty Ltd will pay return freight of its choice. A returned product must be accompanied by a written description of the defect and a photocopy of the original purchase receipt. This receipt must clearly list model and serial number, the date of purchase, the name and address of the purchaser and authorised dealer and the price paid by the purchaser. On receipt of the product, Sealite Pty Ltd will assess the product and advise the customer as to whether the claimed defect is covered by this warranty.
8. Sealite Pty Ltd reserves the right to modify the design of any product without obligation to purchasers of previously manufactured products and to change the prices or specifications of any product without notice or obligation to any person.
9. Input voltage shall not exceed those recommended for the product.
10. Warranty does not cover damage caused by the incorrect replacement of battery in solar lantern models.
11. This warranty does not cover any damage or defect caused to any product as a result of water flooding or any other acts of nature.
12. There are no representations or warranties of any kind by Sealite or any other person who is an agent, employee, or other representative or affiliate of Sealite, express or implied, with respect to condition of performance of any product, their merchantability, or fitness for a particular purpose, or with respect to any other matter relating to any products.

Limitation of Liability

To the extent permitted by section 68A of the Trade Practices Act 1974 (Cth), the liability of Sealite Pty Ltd under this Warranty will be, at the option of Sealite Pty Ltd, limited to either the replacement or repair of any defective product covered by this Warranty. Sealite will not be liable to Buyer for consequential damages resulting from any defect or deficiencies.

Limited to Original Purchaser

This Warranty is for the sole benefit of the original purchaser of the covered product and shall not extend to any subsequent purchaser of the product.

Miscellaneous

Apart from the specific warranties provided under this warranty, all other express or implied warranties relating to the above product is hereby excluded to the fullest extent allowable under law. The warranty does not extend to any lost profits, loss of good will or any indirect, incidental or consequential costs or damages or losses incurred by the purchaser as a result of any defect with the covered product.

Warrantor

Sealite Pty Ltd has authorised distribution in many countries of the world. In each country, the authorised importing distributor has accepted the responsibility for warranty of products sold by distributor. Warranty service should normally be obtained from the importing distributor from whom you purchased your product. In the event of service required beyond the capability of the importer, Sealite Pty Ltd will fulfil the conditions of the warranty. Such product must be returned at the owner's expense to the Sealite Pty Ltd factory, together with a photocopy of the bill of sale for that product, a detailed description of the problem, and any information necessary for return shipment.

Other Sealite Products Available



**Marine Lanterns
(1-12nm+)**



**Monitoring
& Control Systems**



Bridge & Barge Lights



**Marine Buoys
(up to 3mt in diameter)**



Area Lighting



**Mooring Systems
& Accessories**



Sealite
www.sealite.com

Head Office
Sealite Pty Ltd
11 Industrial Drive
Somerville, Vic 3912
Australia
Tel: +61 3 5977 6128
Fax: +61 3 5977 6124
Email: info@sealite.com
Internet: www.sealite.com

