

www.shoremaster.com

# 1200 PW Cantilever Lift:

Part Number:1017507

Instructions and Safety Tips

1200 lbs Capacity

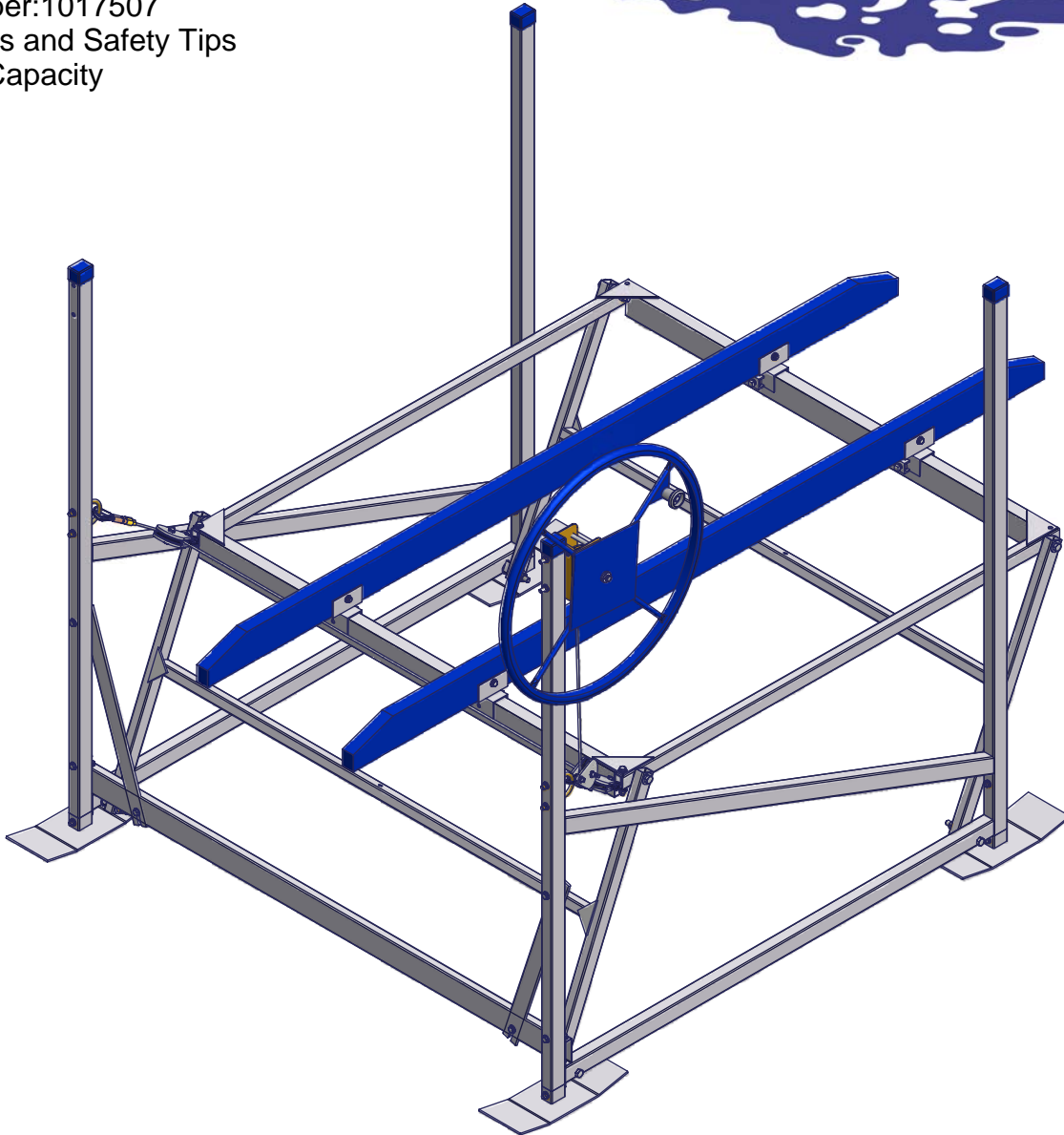

## CAUTION - PUT SAFETY FIRST

1. Before attempting to install or operate this hoist, study and fully understand the proper operating procedures and safety precautions outlined in this owner's manual.
2. Never exceed the recommended weight capacity of your lift. The lifted weight will include hull, engine, fuel, battery, and added accessories or gear. Weigh your fully loaded boat at a certified scale to be absolutely sure of the total weight.
3. Do not allow anyone on, in or under the lift while operating.
4. NOT COMPLYING WITH THE PROCEDURES AND PRECAUTIONS OUTLINED IN THIS MANUAL WILL INVALIDATE THE WARRANTY AND MAY RESULT IN PERSONAL INJURY OR DEATH.
5. If you have any questions about assembly, installation, operation or suitability of this product, contact an authorized dealer.

# ShoreMaster 1200 PW Cantilever Lift

Part Number: 1017507

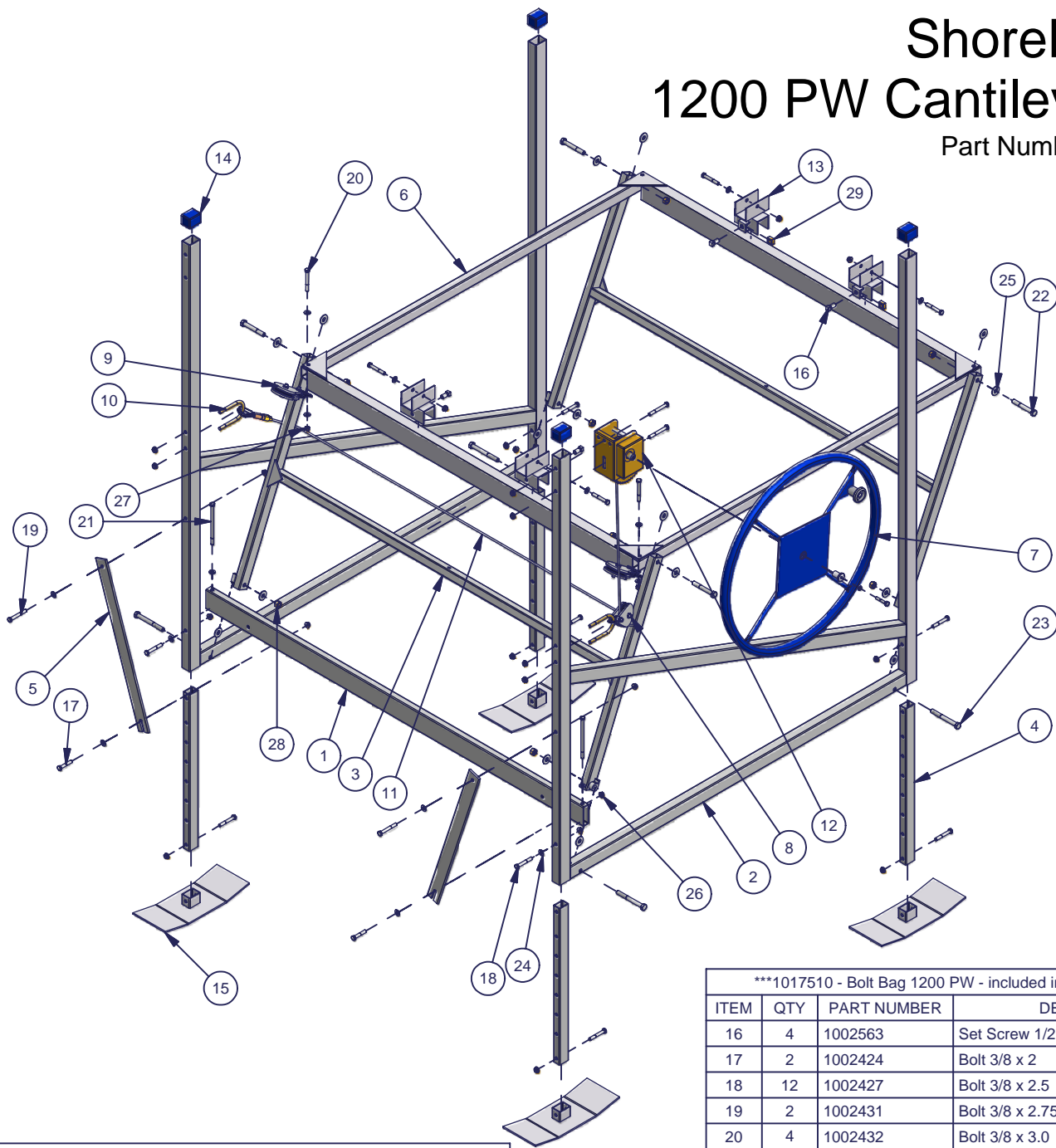

*1017508 - BUNDLE 1200 PW CANTILEVER LIFT*			
ITEM	QTY	PART NUMBER	DESCRIPTION
1	1	1017514	BOTTOM BEAM
2	2	1017511	LIFT SIDE
3	2	1017512	I BEAM
4	4	1005091	LEG POST - B
5	2	1007385	SUPPORT BRACE
6	1	1017513	Rack
7	1	1007448	Wheel Small

*1017509 - 1200 PW WINCH/HARDWARE BOX*			
ITEM	QTY	PART NUMBER	DESCRIPTION
8	1	1007224	Pulley with 2 Chain Links
9	2	1007225	Pulley with 3 Chain Links
10	2	1002372	U Bolt 3/8 x 4
11	1	1017522	Winch Cable
12	1	1002027	Winch 1202
13	4	1005604	Bunk Board Bracket
14	4	1001825	Blue Cap (#4) 1.42 x 1.92
-	1	1013137	Wheel Kit Spacer - DL
15	4	1007382	Foot Pad

***1017510 - Bolt Bag 1200 PW - included in Hardware Box***			
ITEM	QTY	PART NUMBER	DESCRIPTION
16	4	1002563	Set Screw 1/2 x 1.25
17	2	1002424	Bolt 3/8 x 2
18	12	1002427	Bolt 3/8 x 2.5
19	2	1002431	Bolt 3/8 x 2.75
20	4	1002432	Bolt 3/8 x 3.0
21	2	1002446	Bolt Hex 3/8 x 6
22	4	1002383	Bolt 1/2 x 3.5
23	4	1002385	Bolt 1/2 x 4.5
24	20	1002599	Washer Flat 3/8
25	16	1002565	Washer Flat 1/2
26	24	1001802	Nut Flange 3/8
27	2	1001803	Nut 3/8
28	8	1001795	Nut Nyloc 1/2
29	4	1001793	Nut Square 1/2

PULLEY PARTS			
ITEM	QTY	PART NUMBER	DESCRIPTION
	3	1007226	PULLEY COMPLETE LESS CHAIN
	2	1003489	PULLEY SIDE PLATE (ALUM)
	1	1007626	SHEAVE INSERT (STEEL)
	2	1002367	BOLT 3/8 X 1.5
	2	1001806	NUT JAM 3/8 NYLOC
	1	1007688	PLASTIC SHEAVE ASSEMBLY 3.0
	1	1006049	2 - LINK CHAIN 3/16 GALV.
	2	1006050	3 - LINK CHAIN 3/16 GALV.

# ASSEMBLY INSTRUCTIONS

Your safety is the most important issue related to this product.

Fully read and understand each step before proceeding with that step.

Wear protective gloves, clothing and eyewear when assembling and installing the lift.

Do not assemble, install or use this product if items are missing or damaged.

For ease of assembly find a flat area with plenty of room to assemble lift. The following tools will be needed for assembling lift:

1. Pair of 9/16" Wrenches
2. Pair of 3/4" Wrenches
3. Measuring Tape
4. Sharp Knife or Razor

## STEP 1

Insert all four Leg Posts into Foot Pads, secure using one Bolt 3/8 x 2.5 and one Nut Flange 3/8 in each place - as shown.

Insert all four Leg Posts into Lift Sides. At the desired height secure with one Bolt 3/8 x 2.5, one Washer Flat 3/8, and one Nut Flange 3/8 in each place - as shown.

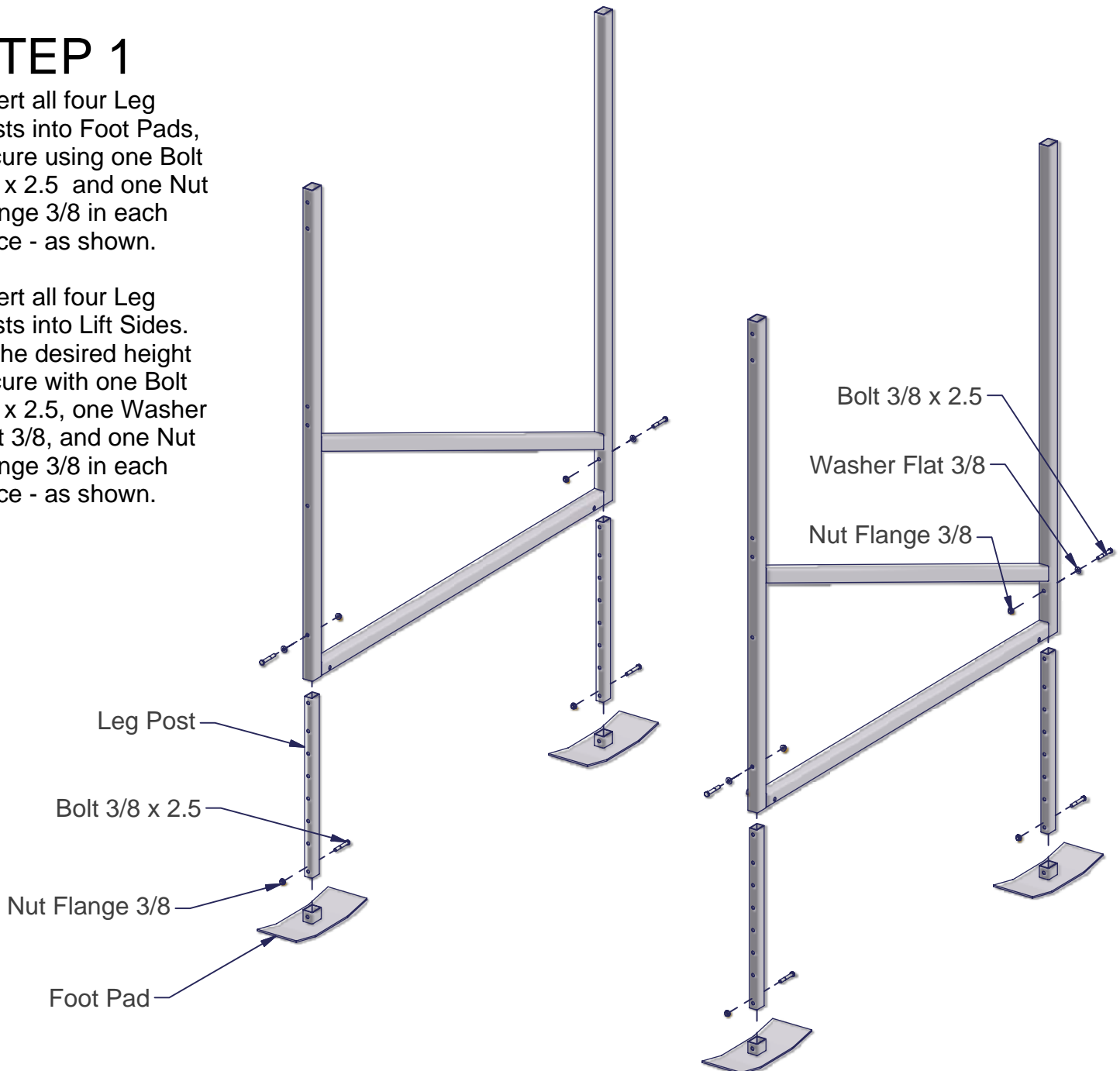

# STEP 2

Place the Lift Sides five feet apart. Attach the Bottom Beam to each Lift Side with one Bolt 3/8 x 6.0, one Washer Flat 3/8, and one Nut Flange 3/8 at each place - as shown.

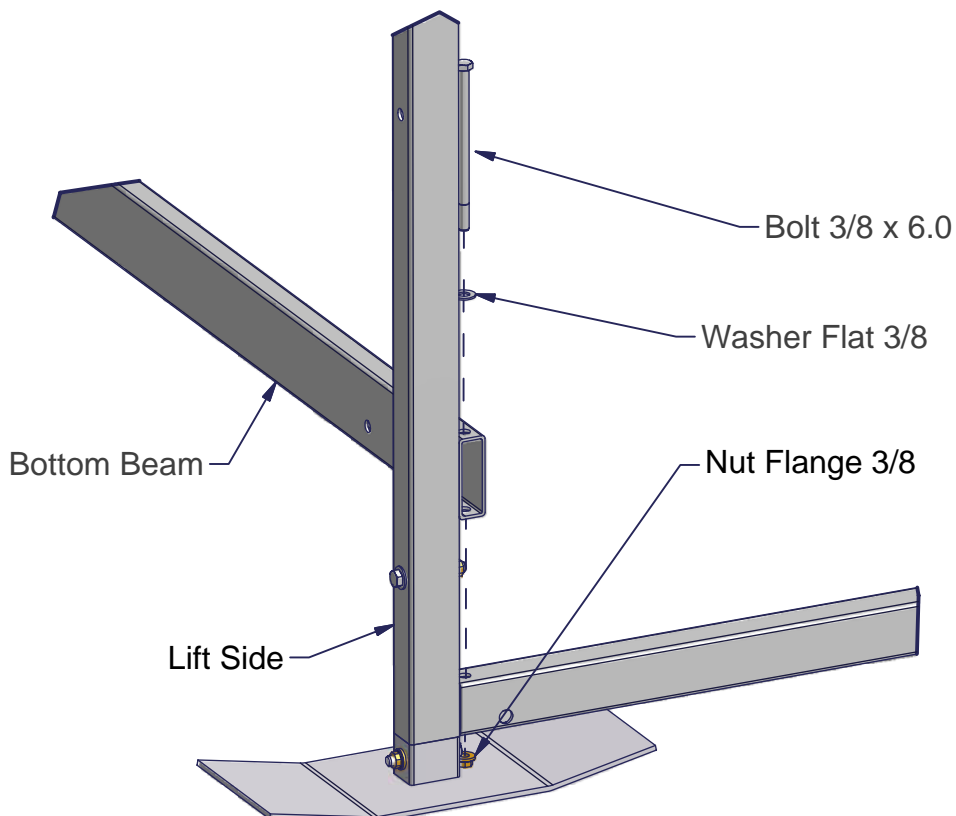
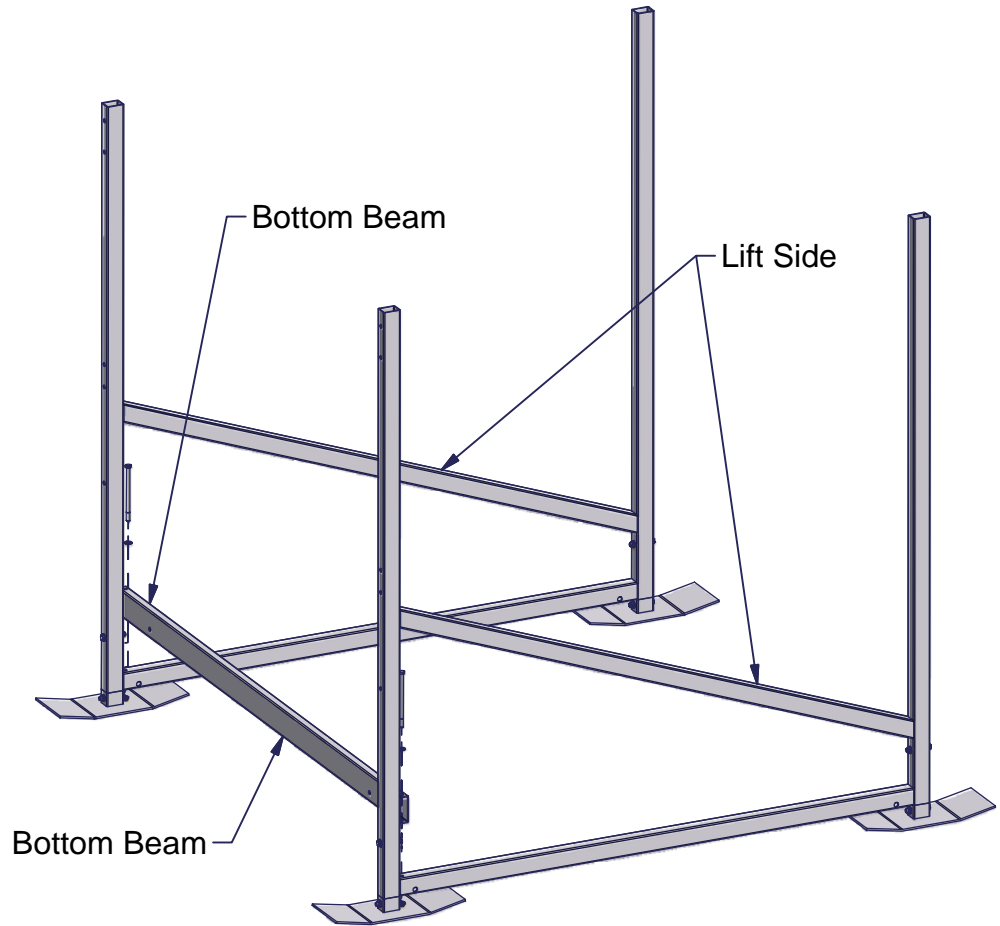

# STEP 3

Attach each I Beam to Lift Side with one Bolt 1/2 x 4.5, two Washers Flat 1/2, and one Nut 1/2 Nyloc in two places - as shown.

**Note:** The Spacer on the I Beam should be positioned at the bottom.

**Note:** Place one Washer Flat 1/2 on the Nut 1/2 Nyloc side and one Washer Flat 1/2 between the I Beam Spacer and the Lift Side - as shown in Detail "A." No Washer is used on the head of the Bolt 1/2 x 4.5.

**Note:** The Nuts should be on the inside of the Lift - as shown.

**Note:** Do not overtighten Nyloc Nuts. Do not reuse Nyloc Nuts. If a Nyloc Nut is removed it must be replaced with a new Nyloc Nut.

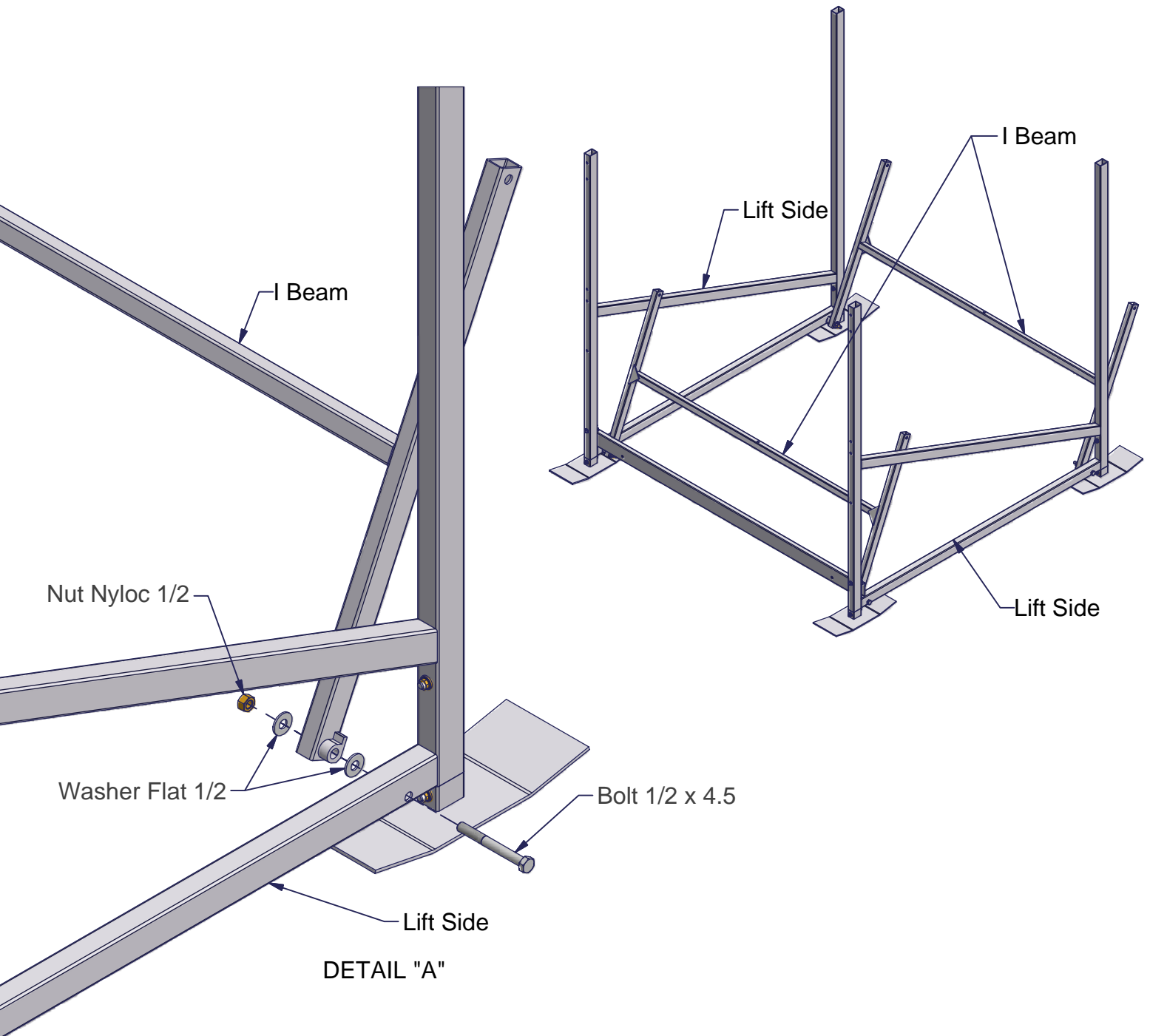

# STEP 4

Attach each Rack Side to the I Beams with one Bolt 1/2 x 3.5, two Washers Flat 1/2, and one Nut 1/2 Nyloc in each corner - as shown.

**Note:** Place one Washer Flat 1/2 on the Bolt 1/2 x 3.5 side and one Washer Flat 1/2 **between the Rack Side and the I Beam** - as shown. No Washer is used on the head of the Nut 1/2 Nyloc.

**Note:** The Nuts should be on the inside of the Lift - as shown.

**Note:** Do not overtighten Nyloc Nuts. Do not reuse Nyloc Nuts. If a Nyloc Nut is removed it must be replaced with a new Nyloc Nut.

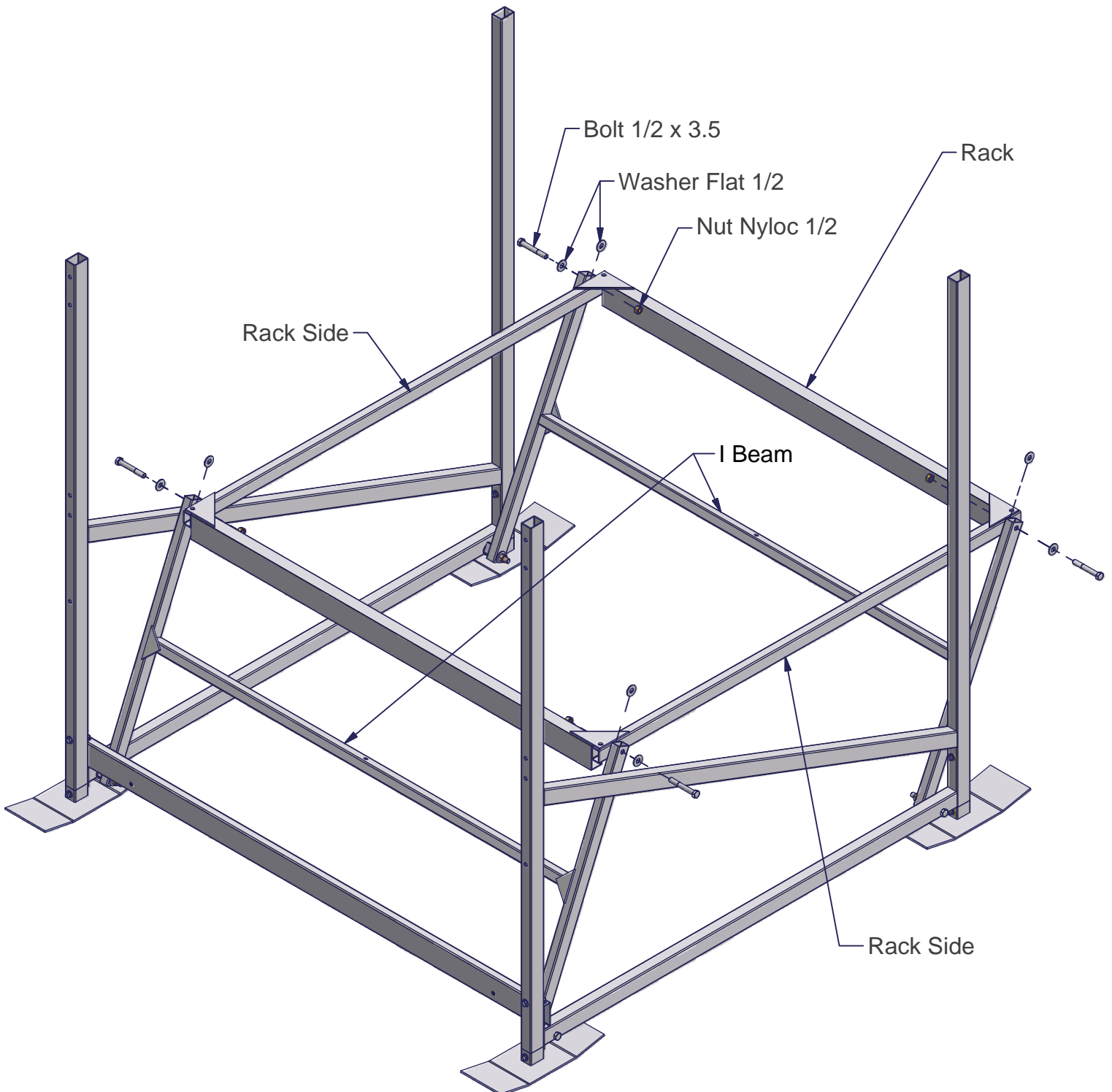

# STEP 5

Attach one Pulley with 3 Chain Links to the bottom of each Rack Side and secure with one Bolt 3/8 x 3, two Washers Flat 3/8, and one Nut 3/8 - as shown in Detail "A."

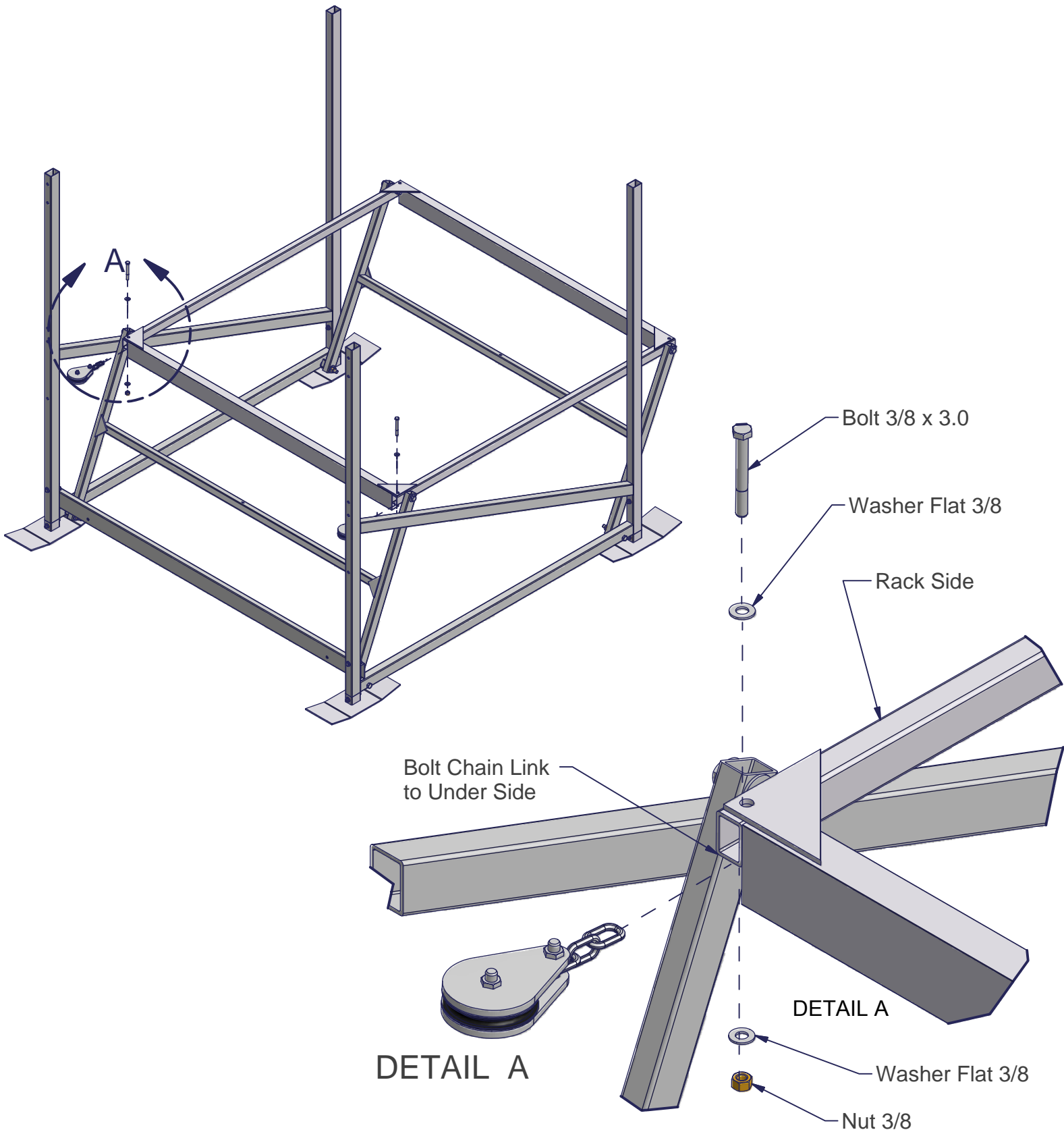

# STEP 6

Attach each Support Brace to the Bottom Beam and one Lift Side in two places - as shown.

Attach the hole side of the Support Brace to one Lift Side with one Bolt 3/8 x 2.75, one Washer Flat 3/8, and one Nut Flange 3/8.

Attach the Slot side of the Support Brace to the Bottom Beam with one Bolt 3/8 x 2.0, one Washer Flat 3/8, and one Nut Flange 3/8.

**Note:** The Support Brace should attach to the outside face of the Bottom Beam and the inside face of the Lift Side.

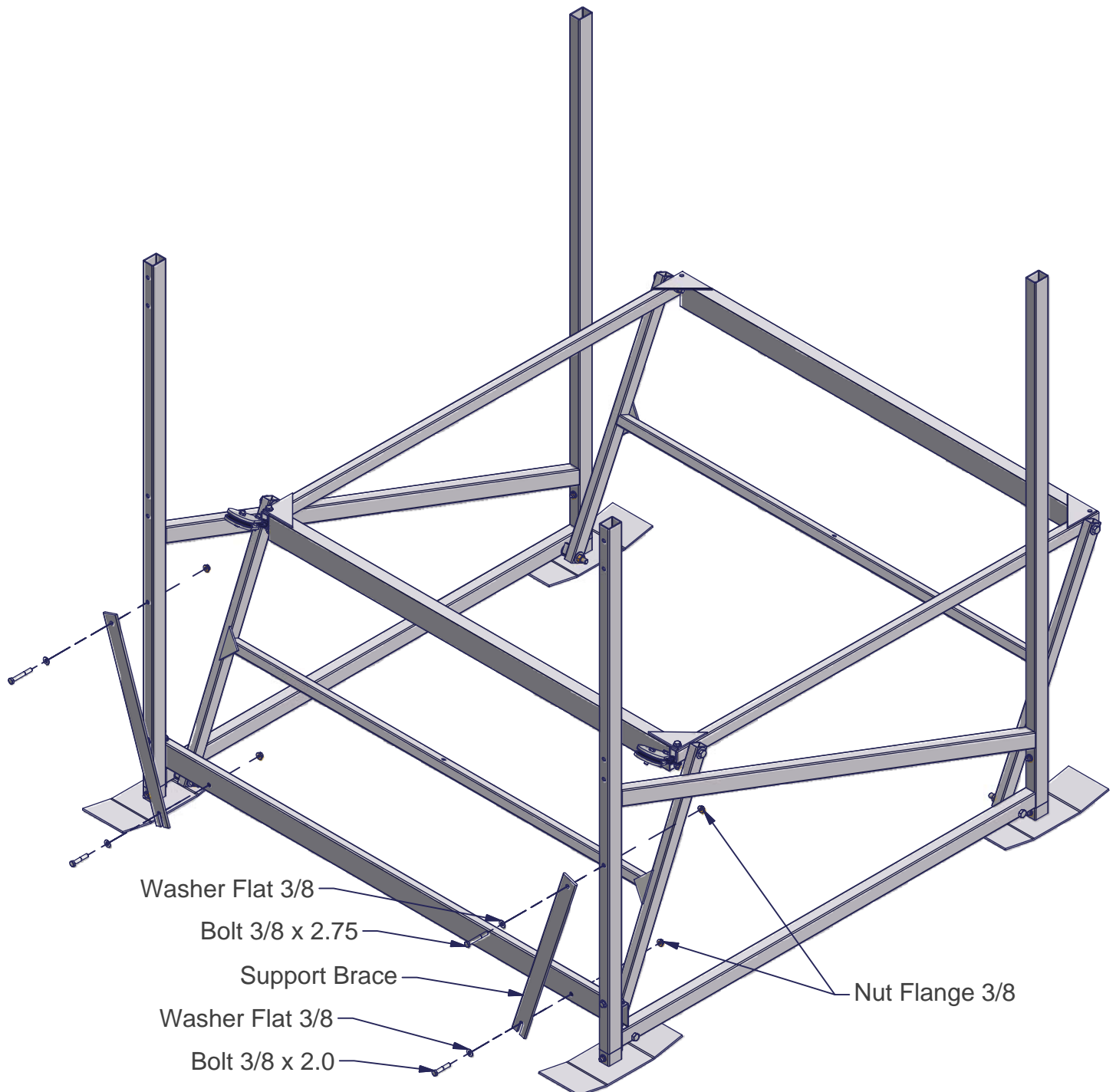



# STEP 7

On the side of the lift that the Winch will be attached, slide the Pulley with 2 Chain Links onto a U Bolt 3/8 x 4 and insert the U Bolt 3/8 x 4 through the two holes on the Lift Side Upright- as shown in Detail "A."

On the opposite side slide the Winch Cable onto a U Bolt 3/8 x 4 and insert the U Bolt 3/8 x 4 through the holes on the Lift Side Upright - as shown in Detail "B."

Secure each U Bolt 3/8 x 4 with two Nuts Flange 3/8 - as shown.

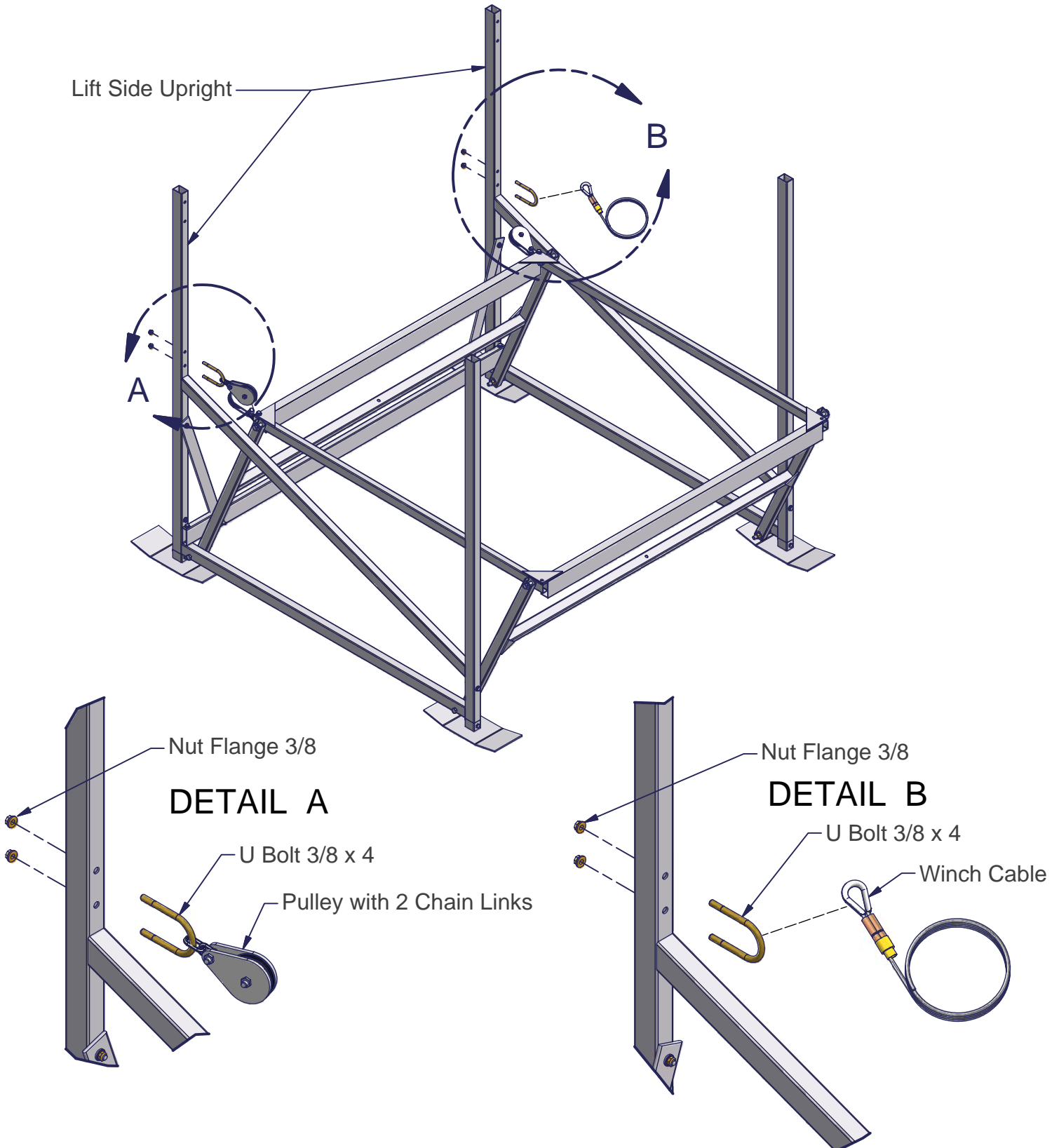

# STEP 8

Route the Winch Cable through the two Pulleys with 3 Chain Links and the one Pulley with 2 Chain Links - as shown.

Note: Wear leather gloves while handling the Winch Cable.

Insert the Winch Cable through the hole in the Winch 1202 Hub and create a loop around the square hole. Secure with one Carriage Bolt 1/4 x .75, one Cable Clamp, and one Nut 1/4 w/ Star Washer as shown in Detail "A."

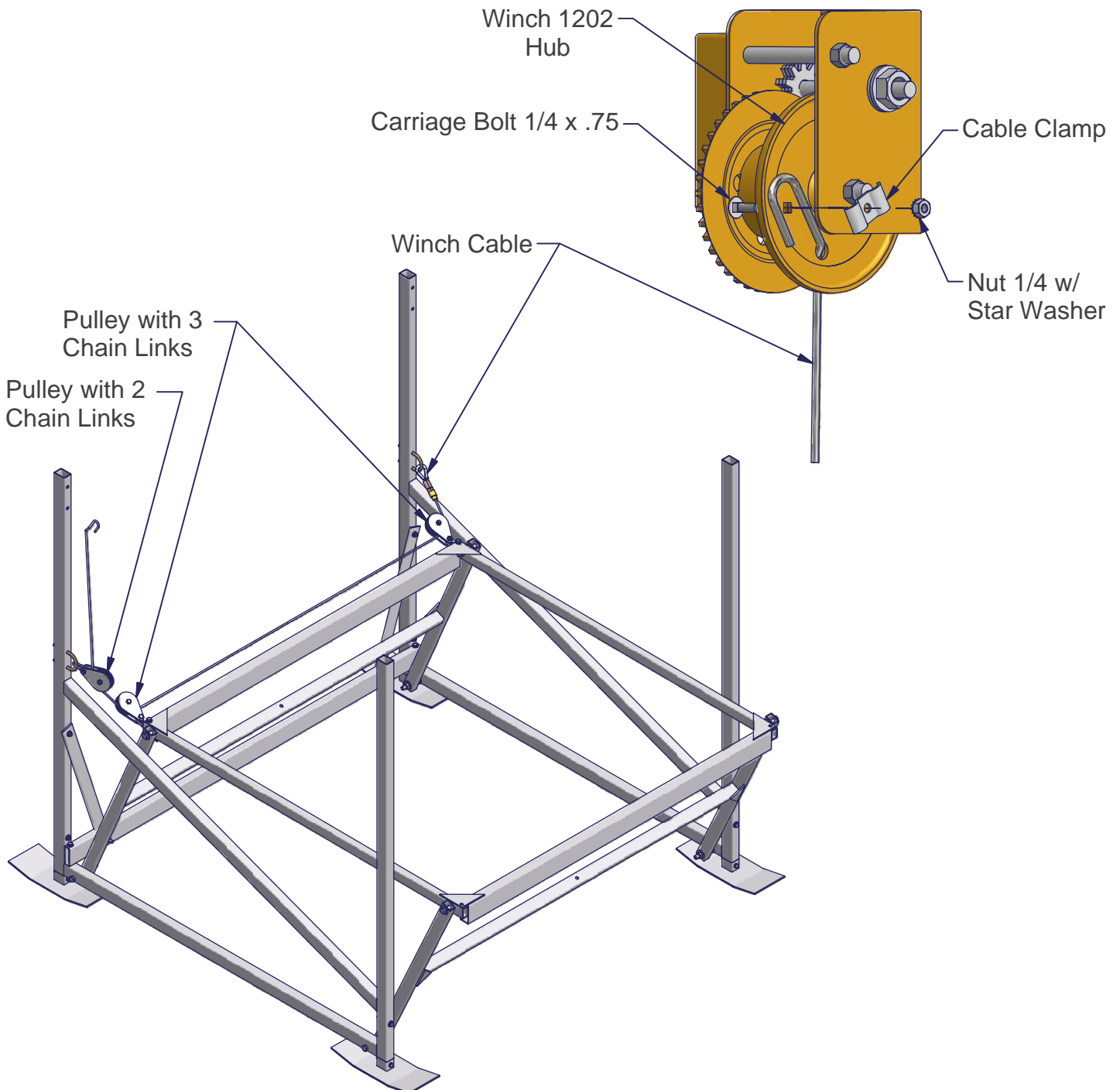

# STEP 9

Attach the Winch 1202 to the Lift Side Upright with two Bolts 3/8 x 3.25, two Nut Flange 3/8 - as shown.

Note: The Bolt Heads should be positioned on the Winch side and should protrude through the Winch 1202 and out the Lift Side Upright - as shown.

Note: The Wheel Shaft of the Winch 1202 must be facing to the outside of the lift. If the Winch 1202 is to be attached to the opposite Lift Side than the one shown it must be up side down from the position shown.

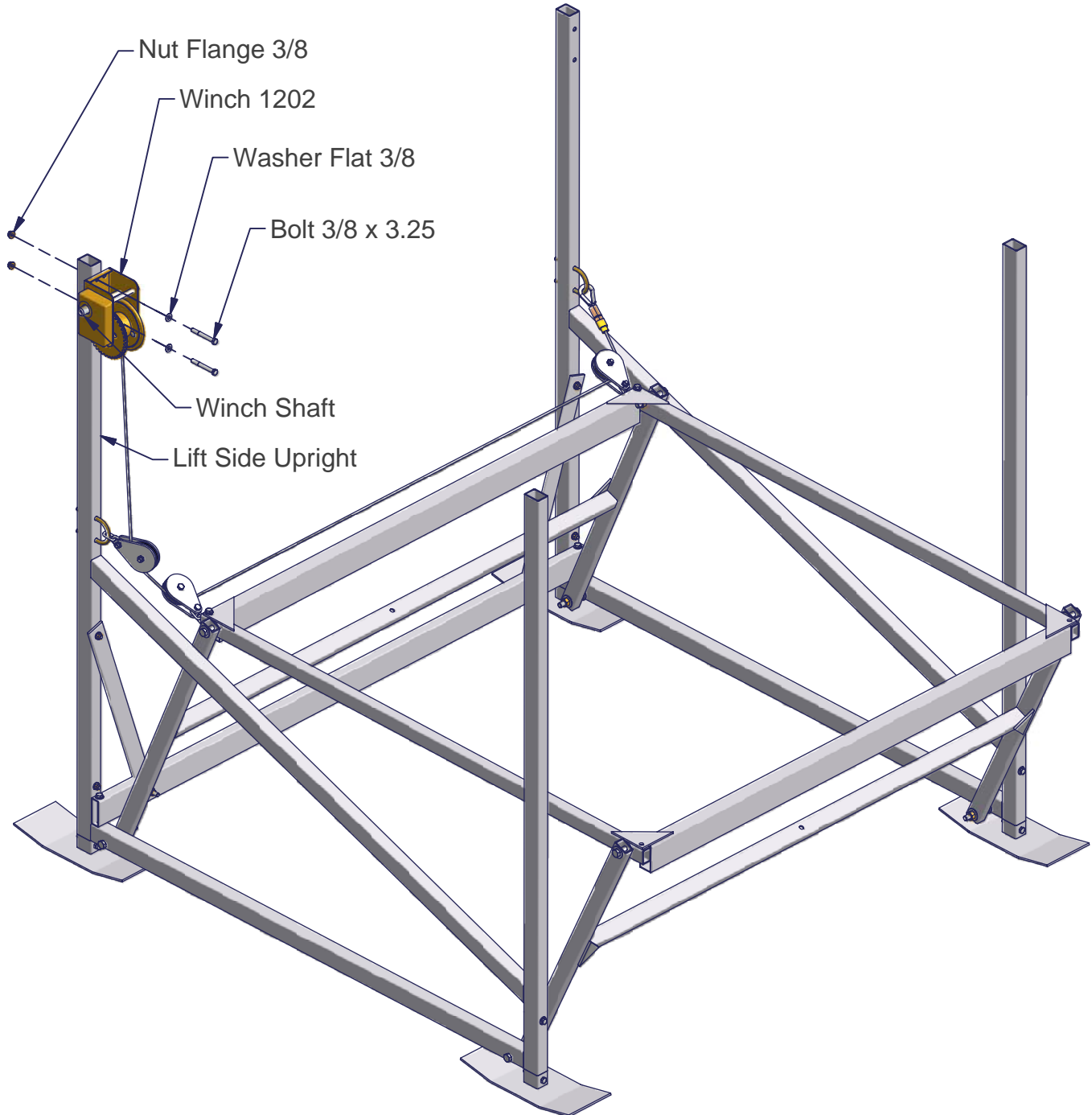

# STEP 10

Thread Wheel clockwise onto Wheel Shaft until it touches the Brake Pad. The wheel must be fully against Brake Pad **and** a clicking sound must be heard when turning wheel up!

Using a sharp knife or razor blade, cut a small hole in the middle of the Wheel, where the wheel sticker covers the attaching bolt hole.

Secure Wheel to Winch 1202 using one Bolt 5/16 x 1.75, one Washer Lock 5/16, and one Wheel Spacer - as shown.

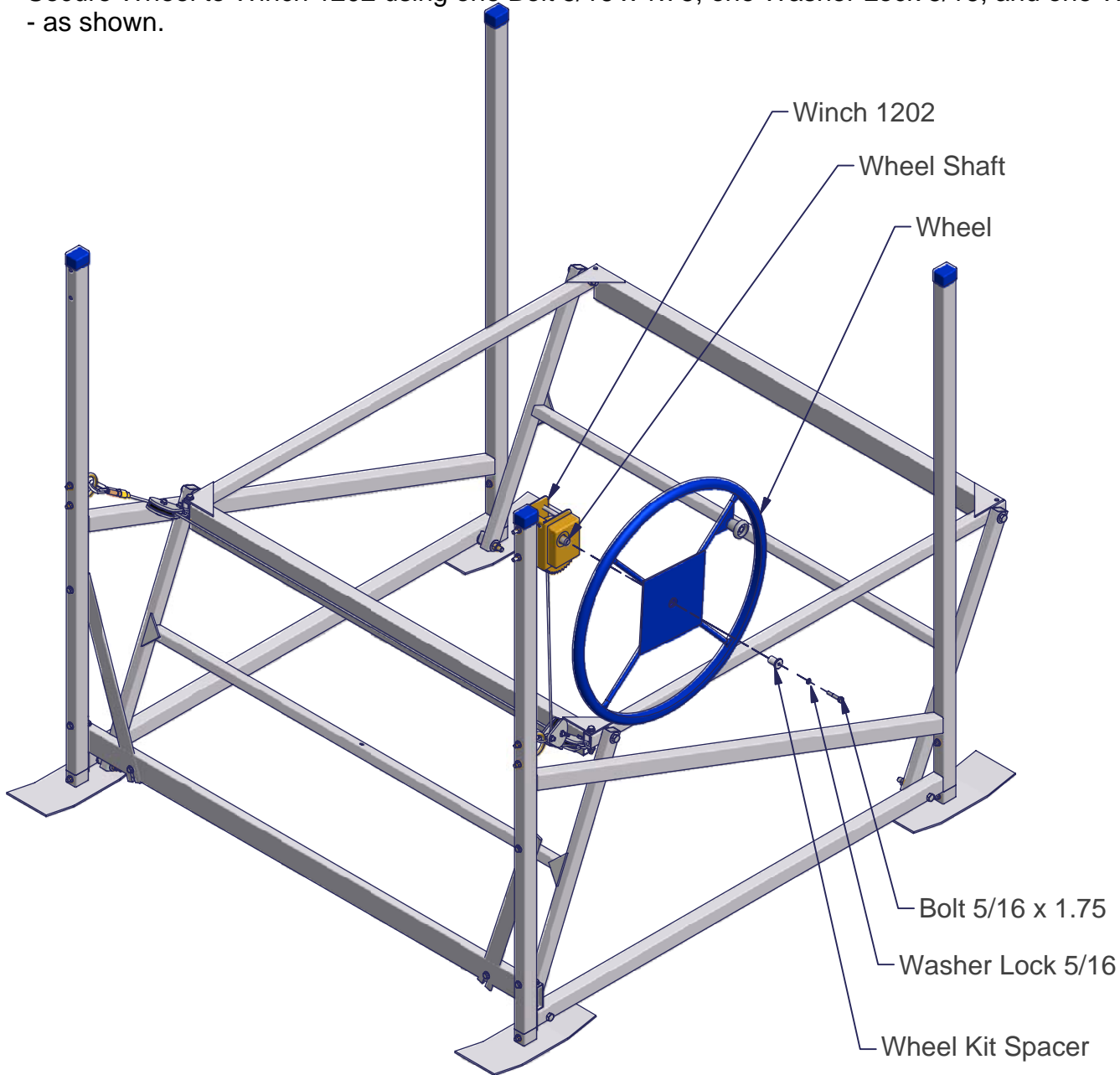

Thread excess cable onto winch hub by turning the wheel clockwise. Be sure cable wraps tight and uniformly on hub with each strand lying snugly next to the adjacent strand. Keep tension on the cable by holding it tight when turning the wheel to develop a proper wrap. Do not allow cable to wind up loosely on hub

## CAUTION

Use a leather glove or other hand protection to avoid cuts when applying cable pressure. Cables wrapping incorrectly will result in rapid cable wear.

# STEP 11

Place four Blue Caps 1.42 x 1.92 over the Lift Side Uprights - as shown.

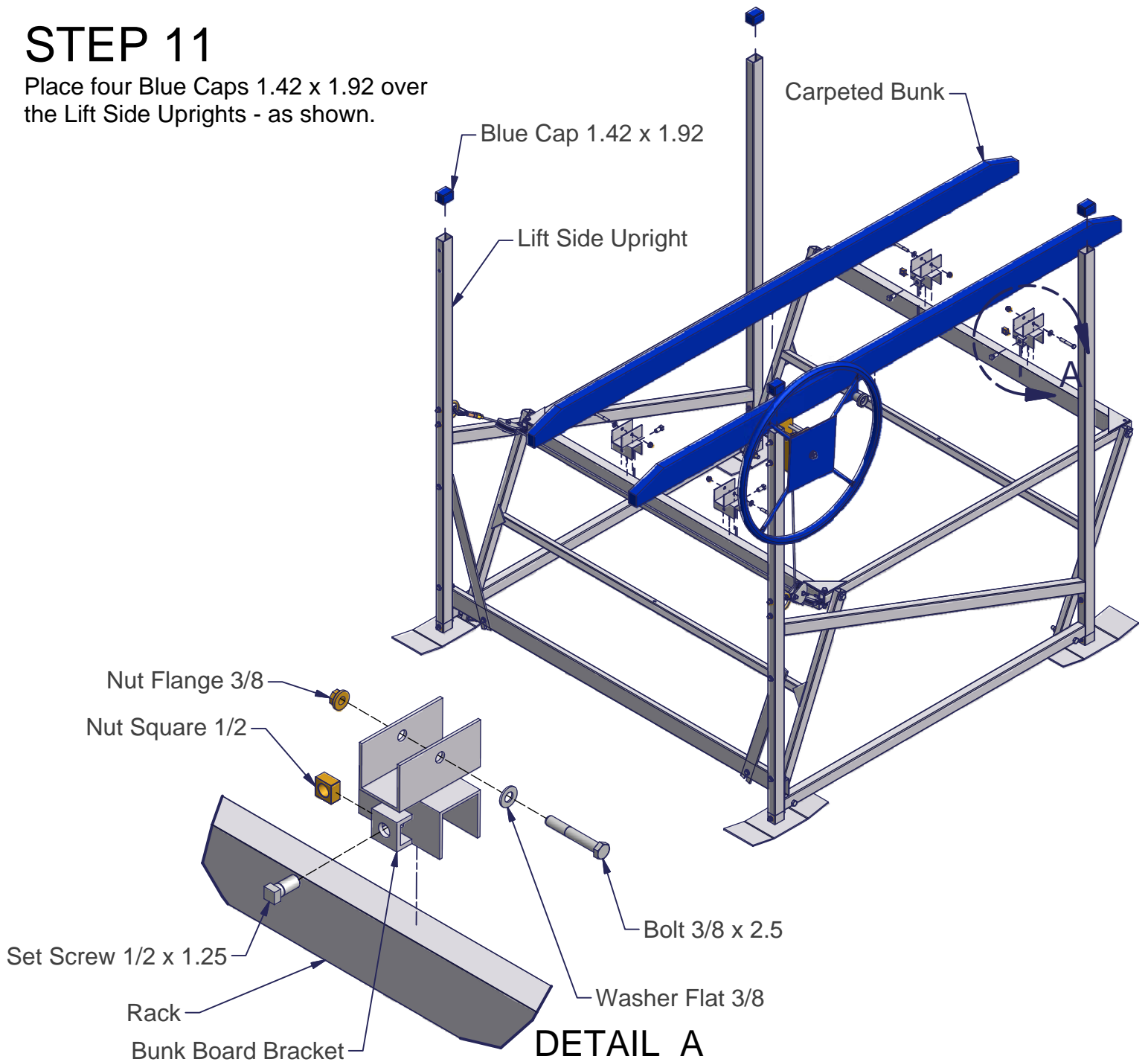

# STEP 12

Position the Bunk Board Brackets on the Rack to fit watercraft. Secure each Bunk Board Bracket with one Nut Square 1/2, and one Set Screw 1/2 x 1.25 - as shown in Detail "A."

Attach optional ShoreMaster Carpeted Bunks to the Bunk Board Brackets with one Bolt 3/8 x 2.5, and one Nut Flange 3/8 in each place - as shown in Detail "A."

Note: The ShoreMaster Carpeted Bunks do not come pre-drilled. The Carpeted Bunks Should be centered on the lift and drilled at each connection point with a 7/16" drill bit.

# STEP 13

Make sure that all nuts and bolt are firmly tightened. Note: Do not over tighten any connection using nyloc nuts or set screw

# INSTALLATION INSTRUCTIONS

Do not under any circumstances, endanger yourself or risk damage to your lift or boat when installing.

- Situations will widely vary between installation sites. ShoreMaster recommends that your dealer or other trained boat lift installer train you and perform the initial installation.
- Wear protective gloves, clothing and eyewear when assembling and installing the lift.
- Do not assemble, install or use this product if items are missing or damaged.

The following are guidelines or suggestions for installation:

## STEP 1

Measure the water depth of the position you want to locate the lift. Measurements should be taken at both the projected position of the end nearest shore and end furthest from shore.

## STEP 2

Before installing, adjust lift legs so the boat can float into position before raising, while still allowing a high enough position so the boat can be fully raised up and out of the water.

## STEP 3

Carry, lift or slide the lift into position alongside the dock.

## STEP 4

Ensure that your lift is level. Measure the distance from the top of the cross beam to the water surface. The distance at each of the four corners of the lift should be within two inches of each other. If they are not, adjust the legs accordingly.

**Note:** If the lift legs will extend 3 feet or more, ShoreMaster recommends deep water braces to stabilize and strengthen the lift. Ask your dealer for more information.

### CAUTION

The lift must be resting on the water bottom in a level, secure and stable position for safe operation. An unstable lift installation could result in tipping of the lift during operation, causing damage to watercraft and a crushing or pinching injury to the operator or bystanders.

## STEP 5

Position the Bunk Bracket to fit watercraft so that it does not come in contact with the frame   
of the lift. After loading and operating the lift pursuant to the operating instructions, remove   
the boat and recheck that the lift remains level.

# OPERATING INSTRUCTIONS

## CAUTION

When first using the boat lift after installation, the weight of the boat may cause the lift to settle and become unbalanced. Until you are certain the lift has stabilized, make sure people are not in the immediate vicinity of the lift.

Now that you have installed and leveled the lift, you are ready to raise your boat for the first time. Prior to use, see to it that anyone who may use the lift looks upon the unit not as a toy but a piece of heavy equipment that deserves your respect and good judgment.

- Before allowing anyone to operate the lift, be sure they fully understand the proper operating procedure.
- Do not exceed maximum capacity of the lift; overloading may cause mechanical failure and serious personal injury.
- Do not allow anyone who is in the water within six feet of the lift.
- Do not allow anyone on, in or under the lift while operating.

When operating the lift, the following procedures should be adhered to:

## STEP 1

Be sure the lift rack and cradles or bunks are positioned below the water surface so they will not interfere with the boat floating into position.

## STEP 2

Properly balance and center the boat on the lift prior to raising. The boat should be positioned with the center of gravity near the middle of the lift. For most rear engine mounted boats, this requires you to position the boat somewhat forward in the lift.

## STEP 3

Turn wheel in direction of arrow (clockwise) to raise lift. A clicking sound is heard when properly raising lift. Turning wheel and wrapping cable in wrong direction may cause fast spin down of wheel.

## WARNING

Stay clear of lifts (facing wheel) while operating. Do not allow anyone on, in or under lift. A cable or lift part failure can cause a sudden drop of boat, resulting in a crushing or falling injury or death!

## CAUTION

Do not touch wheel or attempt to stop it if fast spin down of wheel occurs. Placing hands or feet on spinning wheel can cause broken or cut limbs.

## STEP 4

Carefully bring the lift up until the bunks or cradles have secured the boat. Then, stop the lift and check to see that the bunks or cradles have automatically positioned themselves to the shape of the hull, as they are designed to do. If so, continue bringing the boat out of the water until it is about one foot above the surface. Stop the lift again and check the stability of the lift, particularly to see that it is fairly level and will not topple over. Finally, continue lifting the boat while paying close attention to the positioning of the lift until it is at its desired height.

## STEP 5

After loading and operating the lift, remove the boat and recheck that the lift remains level. (See Step 4 of the Installation Instructions.) If the lift is not level, the legs should be adjusted accordingly. Because the lift may settle and become unbalanced, the lift levelness should be rechecked two weeks after installation and periodically as needed.

## STEP 6

If lift is without a boat in it for more than one day, raise the rack (pulleys) fully out of the water to help prevent corrosion of these parts. At all times, make sure the boat is stored high enough out of the water to avoid wave action against the hull. A moving boat as a result of wave action will damage the lift and can take the boat off the lift.

## CAUTIONS:

1. Do not over raise lift rack. Over raising could cause damage to winch, cable or other parts.
2. Do not over lower rack so slack develops in cable. Doing this could cause cable to jump off winch spool. This may result in sloppy wrapping of cable next time you raise the lift, resulting in premature wear or cable breaking. Turn wheel down one or two turns past point when craft begins to float (This must always be at some point before lift rack is contacting rear bottom beam). Then turn wheel up slightly until clicking sound is heard to secure wheel position and brake on winch.
3. Do not leave lift, or boat on lift, in water if ice formation is possible. Ice can severely damage your boatlift.

## SAFETY MAINTENANCE

### Monthly Checks

Check cables for frays, corrosion or breaks at least once a month. A cable breaking while boat is in lift could damage boat or lift. Severe bodily injury could also occur.

## SPRING AND FALL CHECKS

1. Inspect nuts and bolts for damage, wear or loose connections. Tighten or replace parts as needed.
2. Inspect lift frame, pulleys, winch and pivot points for unusual wear, damage or bent parts. Replace or repair as needed.
3. Lubricate winch and wheel threads. Do not get lubricant on brakepads! Brake will fail and wheel will spin down if brake pads are lubricated.
4. Check and lubricate pulleys to ensure that they are turning freely.
5. Check U Bolts to make sure they are not working themselves loose.

ShoreMaster dealers usually offer service visits. Please contact them if you are unable or unwilling to perform maintenance or service to lift.
---