

© DEN HARTOG INDUSTRIES, INC.

Copyright. All information furnished within this document, electronic file or design correspondence is the property of Den Hartog Industries, Inc. and shall not be used, disclosed to others or copied without the expressed written consent of Den Hartog Industries, Inc.

© FFMB-4242RND ©

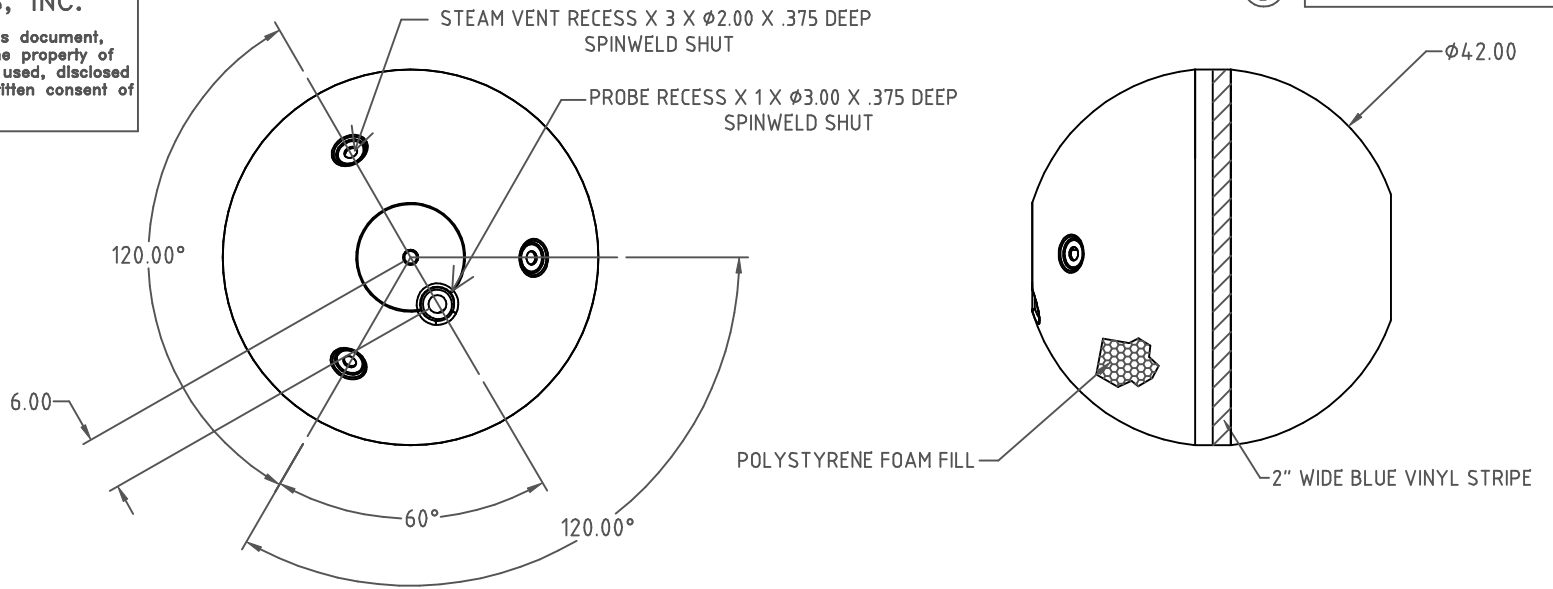

NOTES:

1. SHIPPING WEIGHT = 86 LB.
2. SHIP IN CARTON 19149

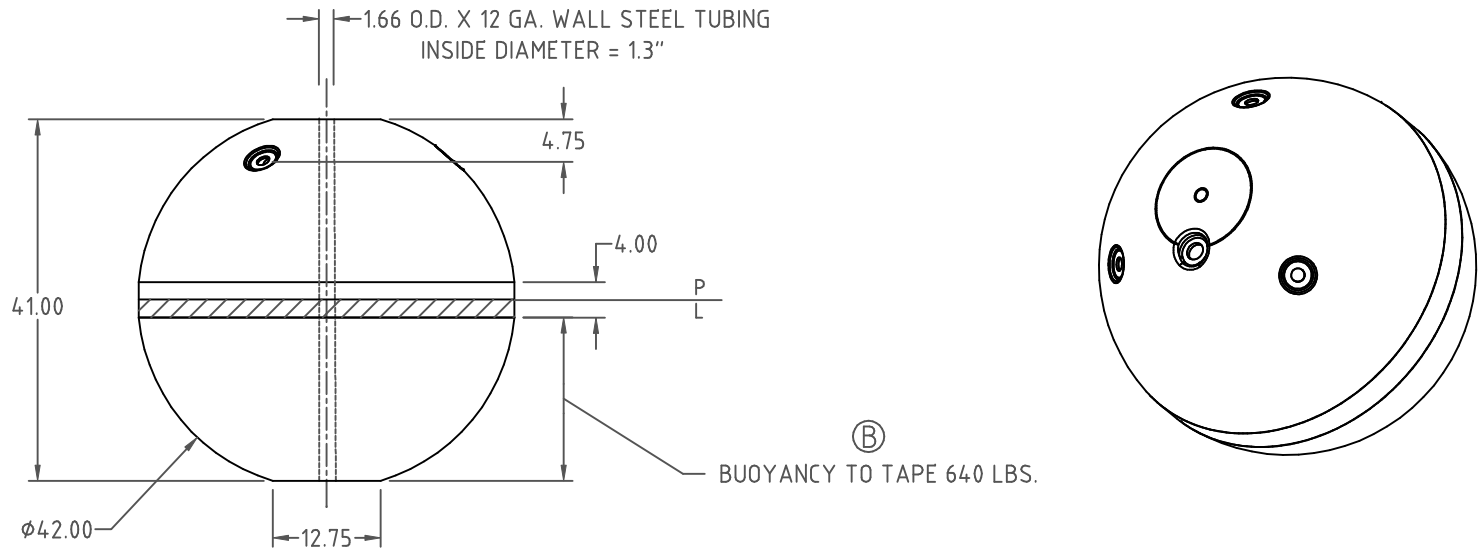

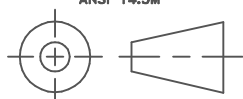
C	CHANGED P.N.	10/27/10 REH	CCN2106	DRAWN / DATE REH/2/6/03	MATERIAL / SHOT WEIGHT	 <p>Ace Roto-Mold A DIVISION OF DEN HARTOG INDUSTRIES, INC. 4010 HOSPERS DRIVE SOUTH, BOX 425, HOSPERS, IA 51238</p>	
B	ADDED USEABLE BUOYANCY	3/28/08 DHJ	CCN1638		E/M 8460, WHITE 54 LB.		
A	SHAFT CUT FLUSH WITH ENDS	5/20/03		APPRD. / DATE DHJ/2/6/03			
REV	DESCRIPTION	DATE	CCN			CLIENT / DESCRIPTION BUOY, 42" DIA.	
ALL DIMENSIONS ARE IN DECIMAL INCHES TOLERANCES UNLESS OTHERWISE SPECIFIED $\pm .5\%$ @ 68° F				THIRD ANGLE PROJECTION ANSI 14.5M 	NOTES: 1. NOMINAL WALL .275	SCALE DOES NOT APPLY	PART NO. FFMB-4242RND