

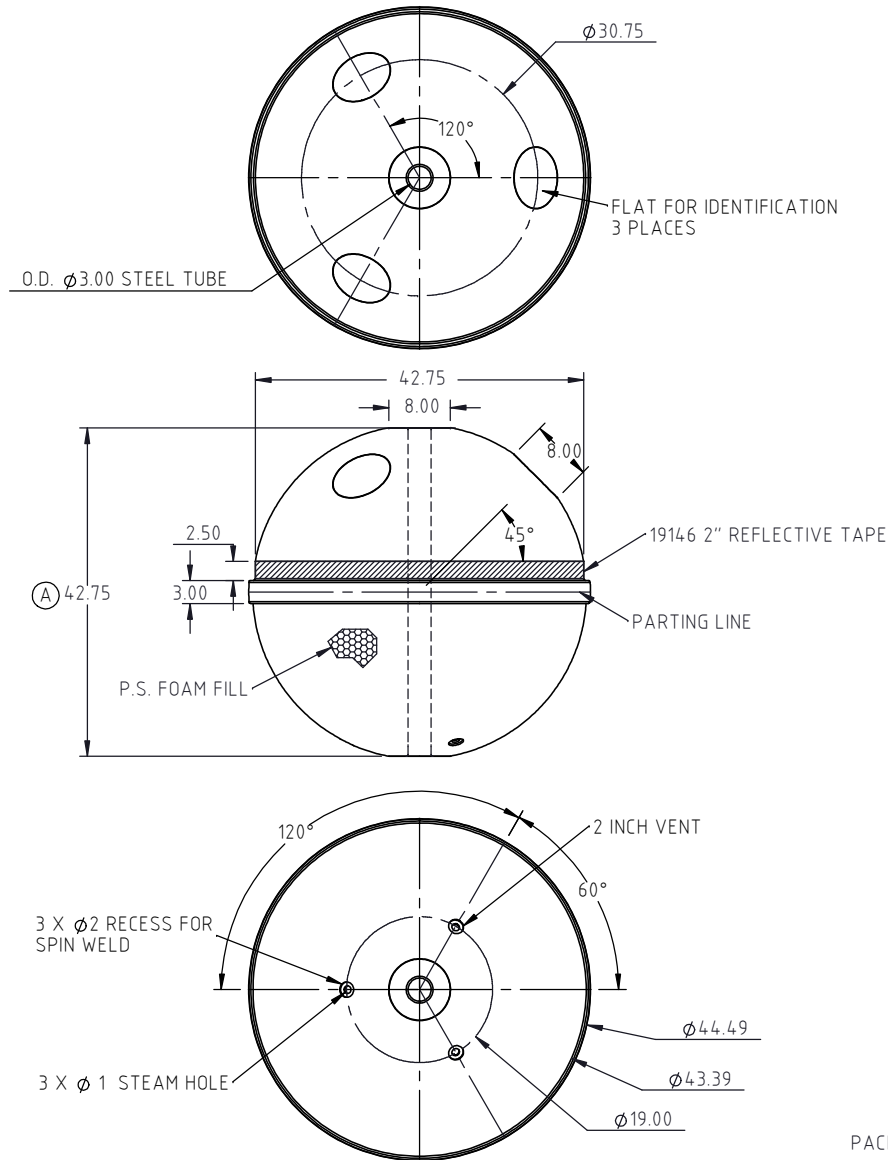
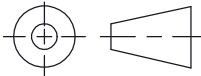

Copyright. All information furnished within this document, electronic file or design correspondence is the property of Den Hartog industries, Inc. and shall not be used, disclosed to others or copied without the expressed written consent of Den Hartog Industries, Inc.



PACKAGE IN 19149 CARTON FOR SHIPMENT

				DRAWN / DATE DHJ 3/24/10	MATERIAL 10948	 <p>Den Hartog INDUSTRIES, INC.</p> <p>Ace Roto-Mold Injection Molding Blow Molding Sowjoy</p> <p>4010 HOSPERS DRIVE S. BOX 425, HOSPERS, IOWA 51238-0425</p>
A	42.75" WAS 41.49"	ADH 1/9/13	2557	APPROD. / DATE REH 10/26/10		
REV	DESCRIPTION	BY / DATE	CCN			
ALL DIMENSIONS ARE IN DECIMAL INCHES TOLERANCES UNLESS OTHERWISE SPECIFIED POLYETHYLENE ±1% @ 68°F		THIRD ANGLE PROJECTION ANSI 14.5M 		SHOT WEIGHT: 54.00 LBS. SHIPPING WEIGHT: 96.00 LBS. FINISH:	NOTES: 1.) .250" WALL 2.) 21.3 LBS. FOAM	DESCRIPTION 42 INCH FOAM FILLED MORING BUOY
				SCALE N.S.	PART NO. FFMB-4242	