

Copyright. All information furnished within this document, electronic file or design correspondence is the property of Den Hartog industries, Inc. and shall not be used, disclosed to others or copied without the expressed written consent of Den Hartog industries, Inc.

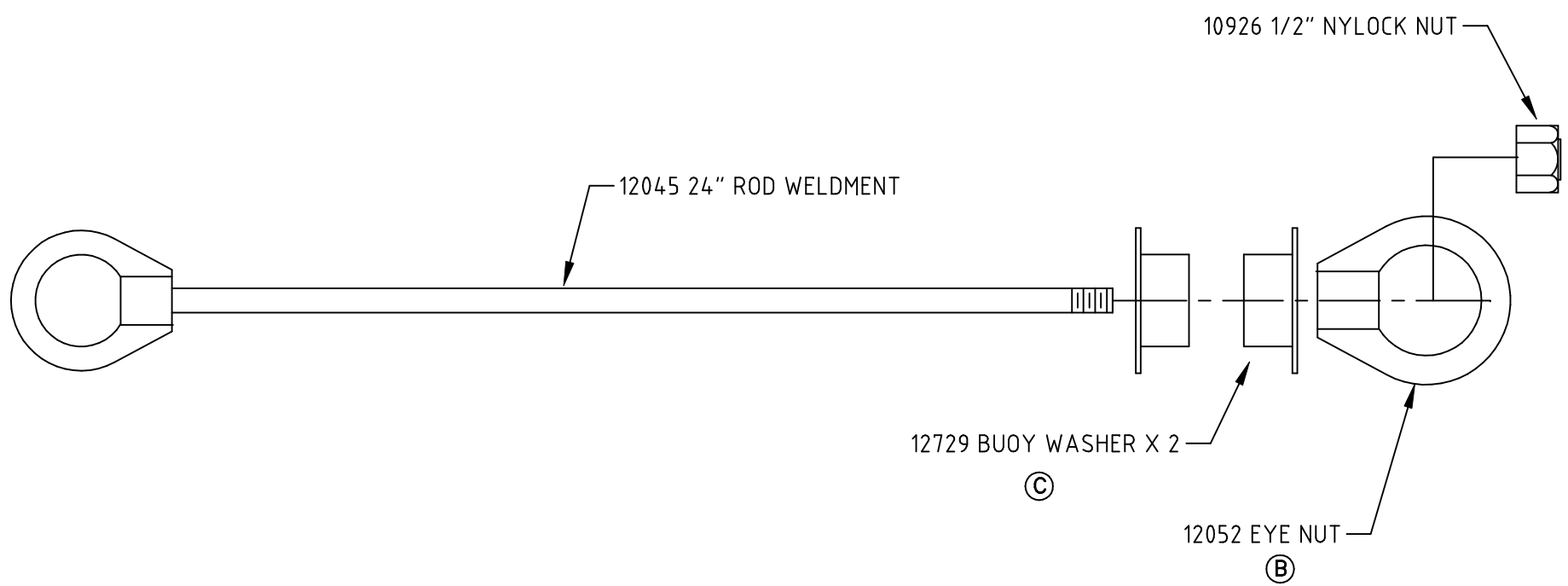

C	12729 REPLACES 19410	DHJ 11/6/09	1959	DRAWN / DATE DHJ 11/6/09	MATERIAL
B	12052 WAS 12038	REH 8/2/06		APPRD. / DATE REH 11/6/09	
A	CHANGED FLAT TO BUOY WASHER	NVE 6/7/06			
REV	DESCRIPTION	BY / DATE	CCN		
ALL DIMENSIONS ARE IN DECIMAL INCHES TOLERANCES UNLESS OTHERWISE SPECIFIED		THIRD ANGLE PROJECTION ANSI 14.5M		SHOT WEIGHT:	NOTES: PACK IN CTN. 12048
POLYETHYLENE		METAL		SHIPPING WEIGHT: 3.5 LB.	
±1% @ 68° F		DECIMAL ± .125" FRACTION ± 1/4" ANGLE ± 1°		FINISH: GALVANIZED	



Den Hartog
INDUSTRIES, INC.

Ace Roto-Mold Injection Molding Blow Molding Sowjoy
4010 HOSPERS DRIVE S. BOX 425, HOSPERS, IOWA 51238-0425

DESCRIPTION		24" FIXED BUOY HARDWARE KIT	
SCALE	N.S.	PART NO.	FFMB-24F